

TECHNICAL SUPPORT MANUAL

Split System Air Conditioner

(C,H,T)4A3

Safety Labeling and Signal Words

DANGER, WARNING, CAUTION, and NOTE

The signal words **DANGER**, **WARNING**, **CAUTION**, and **NOTE** are used to identify levels of hazard seriousness. The signal word **DANGER** is only used on product labels to signify an immediate hazard. The signal words **WARNING**, **CAUTION**, and **NOTE** will be used on product labels and throughout this manual and other manuals that may apply to the product.

DANGER – Immediate hazards which **will** result in severe personal injury or death.

WARNING – Hazards or unsafe practices which **could** result in severe personal injury or death.

CAUTION – Hazards or unsafe practices which **may** result in minor personal injury or product or property damage.

NOTE – Used to highlight suggestions which **will** result in enhanced installation, reliability, or operation.

Signal Words in Manuals

The signal word **WARNING** is used throughout this manual in the following manner:



The signal word **CAUTION** is used throughout this manual in the following manner:



Signal Words on Product Labeling

Signal words are used in combination with colors and/or pictures on product labels.

TABLE OF CONTENTS

Wiring Diagrams	2 – 3
Charging Chart	4
Tech Labels (Expanded Data)	5 – 11
Condenser Only Data	12 – 15
Cooling Multiplying Factors	16 – 20
Exploded Drawings	21 – 23
C4A3 Parts List	24 – 26
H4A3 Parts List	27 – 29
T4A3 Parts List	30 – 32
Model Number Identification	33

DEATH, PERSONAL INJURY, AND/OR PROPERTY DAMAGE HAZARD

Failure to carefully read and follow this warning could result in equipment malfunction, property damage, personal injury and/or death.

Installation or repairs made by unqualified persons could result in equipment malfunction, property damage, personal injury and/or death.

The information contained in this manual is intended for use by a qualified service technician familiar with safety procedures and equipped with the proper tools and test instruments.

Installation must conform with local building codes and with the National Electrical Code NFPA70 current edition or Canadian Electrical Code Part 1 CSA C.22.1.

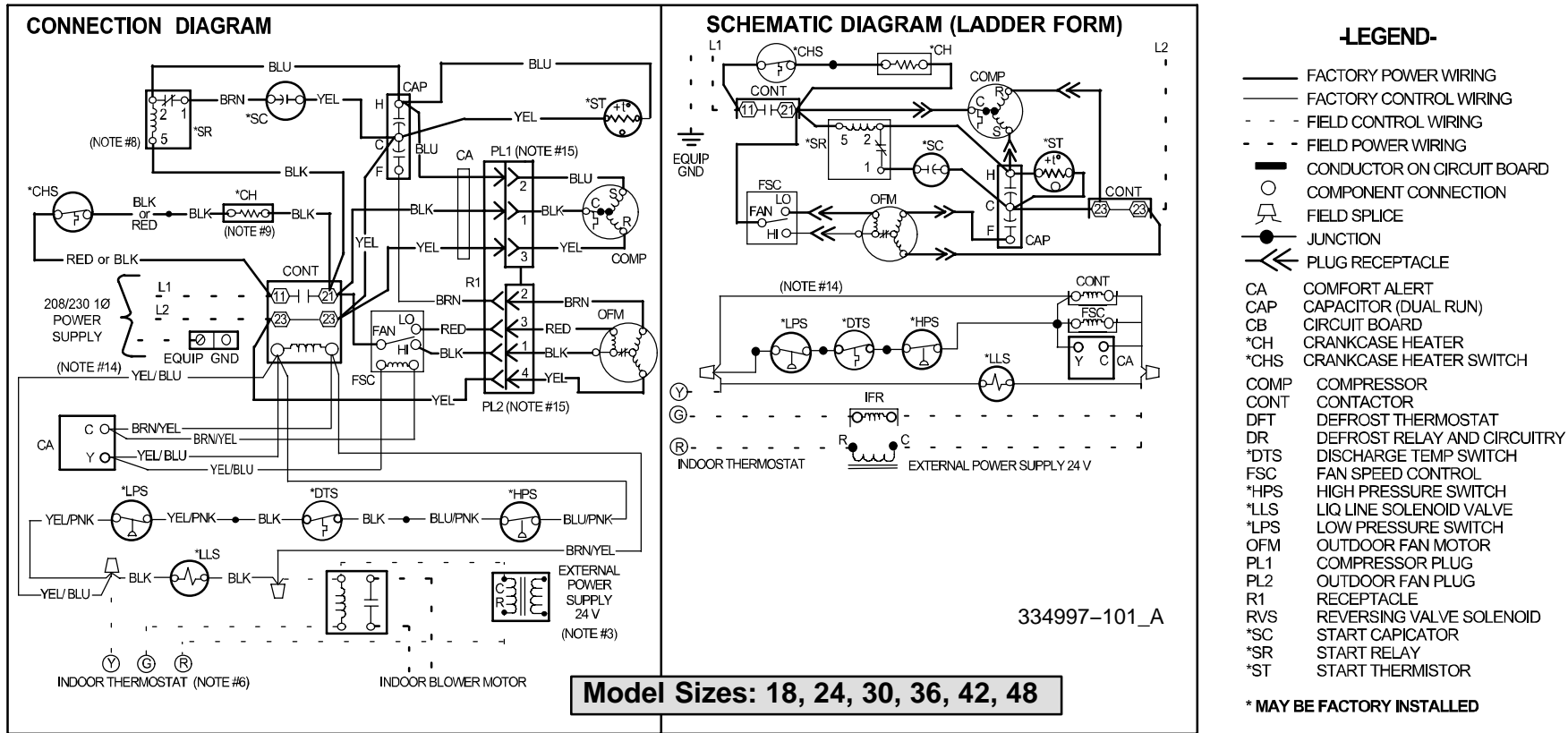

1. Symbols are electrical representation only.
2. Compressor and fan motor furnished with inherent thermal protection.
3. To be wired in accordance with National Electric N.E.C. and local codes.
4. N.E.C. class 2, 24 V circuit, min. 40 VA required, 60 VA on units installed with LLS.
5. Use copper conductors only. Use conductors suitable for at least 75°C (167°F).
6. Connection for typical cooling only thermostat. For other arrangements see installation instructions.
7. If indoor section has a transformer with a grounded secondary, connect the grounded side to the BRN/YEL lead.
8. When start capacitor and relay are installed, start thermistor is not used.
9. CH not used on all units.
10. If any of the original wire, as supplied, must be replaced, use the same or equivalent wire.
11. Check all electrical connections inside control box for tightness.
12. Do not attempt to operate unit until service valves have been opened.
13. Do not rapid cycle compressor. Compressor must be off 3 minutes to allow pressures to equalize between high and low side before starting.
14. Wire not present if HPS, LPS or CTD are used.
15. Not for interrupting current.

CONNECTION DIAGRAM

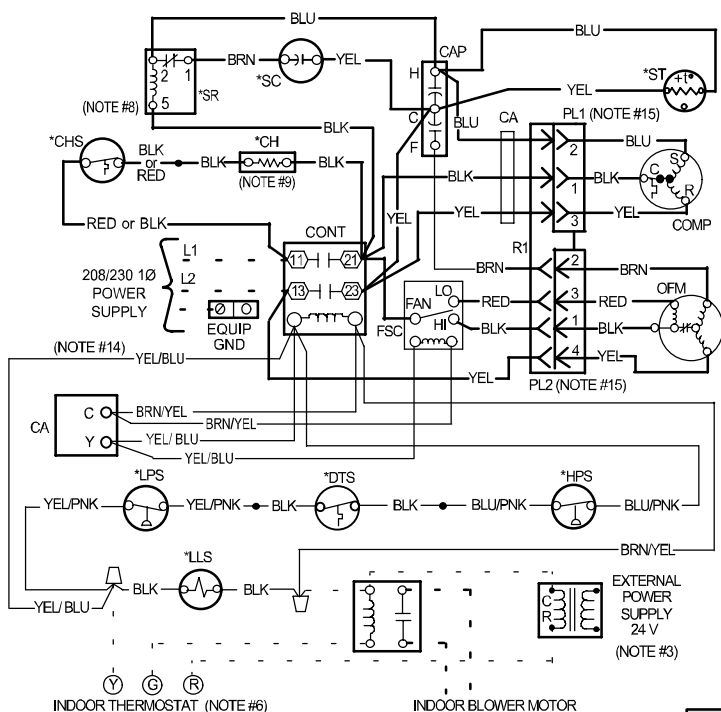

SCHEMATIC DIAGRAM (LADDER FORM)

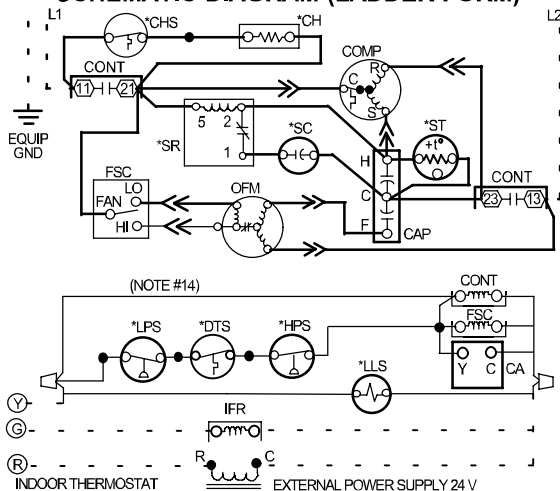

334999-101_A

Model Size: 60

-LEGEND-

—	FACTORY POWER WIRING
---	FACTORY CONTROL WIRING
- · - ·	FIELD CONTROL WIRING
- - -	FIELD POWER WIRING
—	CONDUCTOR ON CIRCUIT BOARD
○	COMPONENT CONNECTION
○	FIELD SPlice
⊕	JUNCTION
⊕	PLUG RECEPTACLE
CA	COMFORT ALERT
CAP	CAPACITOR (DUAL RUN)
CB	CIRCUIT BOARD
*CH	CRANKCASE HEATER
*CHS	CRANKCASE HEATER SWITCH
COMP	COMPRESSOR
CONT	CONTACTOR
DFT	DEFROST THERMOSTAT
DR	DEFROST RELAY AND CIRCUITRY
*DTS	DISCHARGE TEMP SWITCH
FSC	FAN SPEED CONTROL
*HPS	HIGH PRESSURE SWITCH
*LLS	LIQ LINE SOLENOID VALVE
*LPS	LOW PRESSURE SWITCH
OFM	OUTDOOR FAN MOTOR
PL1	COMPRESSOR PLUG
PL2	OUTDOOR FAN PLUG
R1	RECEPTACLE
RVS	REVERSING VALVE SOLENOID
*SC	START CAPICATOR
*SR	START RELAY
*ST	START THERMISTOR

* MAY BE FACTORY INSTALLED

1. Symbols are electrical representation only.
2. Compressor and fan motor furnished with inherent thermal protection.
3. To be wired in accordance with National Electric N.E.C. and local codes.
4. N.E.C. class 2, 24 V circuit, min. 40 VA required, 60 VA on units installed with LLS.
5. Use copper conductors only. Use conductors suitable for at least 75°C (167°F).
6. Connection for typical cooling only thermostat. For other arrangements see installation instructions.
7. If indoor section has a transformer with a grounded secondary, connect the grounded side to the BRN/YEL lead.
8. When start capacitor and relay are installed, start thermistor is not used.
9. CH not used on all units.
10. If any of the original wire, as supplied, must be replaced, use the same or equivalent wire.
11. Check all electrical connections inside control box for tightness.
12. Do not attempt to operate unit until service valves have been opened.
13. Do not rapid cycle compressor. Compressor must be off 3 minutes to allow pressures to equalize between high and low side before starting.
14. Wire not present if HPS, LPS or CTD are used.
15. Not for interrupting current.

R-410A CHARGING CHART												
Measured Liquid Pressure (psig)	Rating Plate (required) Subcooling Temperature °F (°C)											
	°F 6	(°C) 3	°F 8	(°C) 4	°F 10	(°C) 6	°F 12	(°C) 7	F 14	(°C) 8	F 16	(°C) 9
	R-410A Required Liquid Line Temperature °F (°C)											
251	78	26	76	24	74	23	72	22	70	21	68	20
259	80	27	78	26	76	24	74	23	72	22	70	21
266	82	28	80	27	78	26	76	24	74	23	72	22
274	84	29	82	28	80	27	78	26	76	24	74	23
283	86	30	84	29	82	28	80	27	78	26	76	24
291	88	31	86	30	84	29	82	28	80	27	78	26
299	90	32	88	31	86	30	84	29	82	28	80	27
308	92	33	90	32	88	31	86	30	84	29	82	28
317	94	34	92	33	90	32	88	31	86	30	84	29
326	96	36	94	34	92	33	90	32	88	31	86	30
335	98	37	96	36	94	34	92	33	90	32	88	31
345	100	38	98	37	96	36	94	34	92	33	90	32
364	104	40	102	39	100	38	98	37	96	36	94	34
374	106	41	104	40	102	39	100	38	98	37	96	36
384	108	42	106	41	104	40	102	39	100	38	98	37
395	110	43	108	42	106	41	104	40	102	39	100	38
406	112	44	110	43	108	42	106	41	104	40	102	39
416	114	46	112	44	110	43	108	42	106	41	104	40
427	116	47	114	46	112	44	110	43	108	42	106	41
439	118	48	116	47	114	46	112	44	110	43	108	42
450	120	49	118	48	116	47	114	46	112	44	110	43
462	122	50	120	49	118	48	116	47	114	46	112	44
474	124	51	122	50	120	49	118	48	116	47	114	46

COOLING		18 Size Outdoor With ED*4X18B** Indoor Cooling																								
		Outdoor Ambient Temperature – Degrees F, Dry Bulb																								
		75					85					95					105					115				
CFM		Entering Indoor Temperature – Degrees F, Wet Bulb																								
		72	67	63††	62	57	72	67	63††	62	57	72	67	63††	62	57	72	67	63††	62	57	72	67	63††	62	57
525	MBh†	20.29	18.68	17.49	17.19	16.69	19.40	17.84	16.69	16.42	16.06	18.45	16.95	15.84	15.60	15.39	17.52	16.05	14.96	14.77	14.69	16.49	15.07	14.01	13.93	13.93
	S/T‡	0.50	0.67	0.69	0.86	1.00	0.50	0.68	0.70	0.88	1.00	0.51	0.69	0.72	0.90	1.00	0.52	0.71	0.74	0.92	1.00	0.53	0.73	0.76	1.00	1.00
	AMPS*	5.38	5.39	5.40	5.40	5.41	6.02	6.04	6.05	6.05	6.05	6.73	6.75	6.76	6.76	6.76	7.52	7.54	7.55	7.55	7.55	8.39	8.40	8.41	8.41	8.41
	HI PR	286	282	279	279	277	329	325	322	321	321	376	372	369	368	368	429	424	421	421	421	485	482	479	479	479
	LO PR	155	142	132	130	126	158	144	134	132	129	160	146	136	135	133	162	149	139	137	137	165	151	141	141	141
600	MBh†	20.65	18.98	17.80	17.56	17.35	19.66	18.12	16.97	16.78	16.69	18.69	17.20	16.09	15.96	15.98	17.73	16.28	15.19	15.24	15.24	16.67	15.27	14.22	14.43	14.44
	S/T‡	0.51	0.70	0.72	0.90	1.00	0.52	0.71	0.74	0.92	1.00	0.53	0.73	0.75	1.00	1.00	0.54	0.75	0.77	1.00	1.00	0.55	0.77	0.80	1.00	1.00
	AMPS*	5.49	5.51	5.52	5.52	5.52	6.14	6.15	6.16	6.16	6.16	6.85	6.86	6.87	6.87	6.87	7.64	7.65	7.66	7.66	7.66	8.50	8.52	8.53	8.52	8.52
	HI PR	287	283	280	280	279	330	326	323	323	322	377	373	370	370	370	430	425	422	422	422	486	482	480	480	480
	LO PR	159	145	135	134	132	161	147	137	136	136	163	150	139	139	139	165	152	142	143	143	168	154	144	147	147
675	MBh†	20.88	19.19	18.02	17.91	17.89	19.84	18.31	17.18	17.19	17.19	18.84	17.37	16.28	16.44	16.44	17.87	16.44	15.36	15.68	15.68	16.79	15.41	14.37	14.84	14.84
	S/T‡	0.53	0.73	0.75	0.99	1.00	0.54	0.74	0.77	1.00	1.00	0.55	0.76	0.79	1.00	1.00	0.56	0.79	0.81	1.00	1.00	0.57	0.81	0.84	1.00	1.00
	AMPS*	5.61	5.62	5.63	5.63	5.63	6.25	6.27	6.28	6.28	6.28	6.96	6.98	6.99	6.98	6.98	7.75	7.77	7.78	7.77	7.77	8.62	8.63	8.64	8.64	8.64
	HI PR	288	284	281	281	281	331	327	324	324	324	378	374	371	371	371	430	426	423	424	424	487	483	480	482	482
	LO PR	162	148	138	138	138	164	150	140	141	141	166	152	142	144	144	168	154	144	148	148	170	157	146	151	151

- † Total capacities are net (I.D. blower heat subtracted) system capacities based on 25' line set.
If additional tubing length and/or indoor unit is located above outdoor unit, a slight variation in capacity may occur.
- †† At TVA rating indoor condition (75 °F db, 63 °F wb), all other indoor air temperatures are at 80 °F db
If additional tubing length and/or indoor unit is located above outdoor unit, a slight variation in capacity may occur.
- ^ System amps are total of indoor and outdoor amps.
- ‡ Chart data is for 80° F indoor dry bulb. For indoor db temperatures other than 80° F, measure Indoor db and Indoor CFM, and plug these into the formula below. Measure outdoor db and indoor wet bulb, apply these to the chart above, find MBh and S/T, and plug these into the formula below.
(Note: if indoor db is the only thing changing, total capacity, MBh, stays the same.)

Sensible Capacity at Indoor db LOWER than 80 °F = (MBh x S/T) - $\left(\frac{(80 - \text{Indoor db}) \times 835 \times \text{Indoor CFM}}{1000} \right)$

Sensible Capacity at Indoor db HIGHER than 80 °F = (MBh x S/T) + $\left(\frac{(\text{Indoor db} - 80) \times 835 \times \text{Indoor CFM}}{1000} \right)$

COOLING		24 Size Outdoor With ED*4X24B** Indoor Cooling																								
		Outdoor Ambient Temperature – Degrees F, Dry Bulb																								
		75					85					95					105					115				
		Entering Indoor Temperature – Degrees F, Wet Bulb																								
CFM		72	67	63††	62	57	72	67	63††	62	57	72	67	63††	62	57	72	67	63††	62	57	72	67	63††	62	57
700	MBh†	27.06	24.87	23.36	22.98	22.41	25.82	23.82	22.35	22.00	21.61	24.64	22.70	21.28	20.97	20.75	23.44	21.55	20.16	19.92	19.85	22.11	20.30	18.96	18.88	18.88
	S/T‡	0.51	0.68	0.71	0.88	1.00	0.51	0.69	0.72	0.90	1.00	0.52	0.71	0.73	0.92	1.00	0.53	0.73	0.75	0.94	1.00	0.54	0.75	0.77	1.00	1.00
	AMPS*	7.18	7.15	7.14	7.13	7.13	8.02	8.00	7.98	7.98	7.98	8.95	8.93	8.92	8.92	8.91	9.99	9.97	9.97	9.96	9.96	11.13	11.12	11.13	11.12	11.12
	HI PR	291	286	283	283	281	335	330	327	326	325	383	378	375	374	374	436	431	428	427	427	493	489	486	486	486
	LO PR	156	142	132	130	127	158	144	134	132	130	160	146	136	135	133	162	148	138	137	137	164	151	141	141	141
800	MBh†	27.50	25.24	23.74	23.44	23.25	26.14	24.15	22.70	22.46	22.41	24.93	23.00	21.59	21.49	21.49	23.69	21.83	20.45	20.55	20.55	22.33	20.54	19.21	19.52	19.52
	S/T‡	0.52	0.71	0.74	0.92	1.00	0.53	0.73	0.75	0.94	1.00	0.54	0.75	0.77	1.00	1.00	0.55	0.76	0.79	1.00	1.00	0.56	0.79	0.81	1.00	1.00
	AMPS*	7.35	7.32	7.30	7.30	7.29	8.18	8.16	8.14	8.14	8.14	9.11	9.09	9.08	9.08	9.08	10.15	10.13	10.13	10.12	10.12	11.29	11.28	11.29	11.28	11.28
	HI PR	292	287	284	284	283	336	331	328	328	327	384	379	376	376	376	437	432	429	429	429	494	489	487	487	487
	LO PR	159	146	135	134	133	161	148	137	136	136	163	149	139	139	139	165	151	141	143	143	167	154	143	146	146
900	MBh†	27.78	25.51	24.01	23.92	23.93	26.38	24.39	22.95	23.04	23.04	25.12	23.21	21.82	22.08	22.08	23.86	22.02	20.65	21.10	21.10	22.46	20.71	19.39	20.03	20.03
	S/T‡	0.54	0.75	0.77	1.00	1.00	0.55	0.76	0.79	1.00	1.00	0.56	0.78	0.81	1.00	1.00	0.57	0.80	0.83	1.00	1.00	0.59	0.83	0.85	1.00	1.00
	AMPS*	7.51	7.48	7.46	7.46	7.46	8.34	8.32	8.30	8.30	8.30	9.27	9.25	9.24	9.24	9.24	10.31	10.29	10.28	10.28	10.28	11.44	11.44	11.44	11.44	11.44
	HI PR	293	288	285	285	285	337	332	329	329	329	385	380	377	377	377	438	433	429	431	431	495	490	487	489	489
	LO PR	162	148	138	138	138	164	150	140	141	141	166	152	142	144	144	168	154	144	148	148	170	156	146	151	151

- † Total capacities are net (I.D. blower heat subtracted) system capacities based on 25' line set.
If additional tubing length and/or indoor unit is located above outdoor unit, a slight variation in capacity may occur.
- †† At TVA rating indoor condition (75 °F db, 63 °F wb), all other indoor air temperatures are at 80 °F db
If additional tubing length and/or indoor unit is located above outdoor unit, a slight variation in capacity may occur.
- ^ System amps are total of indoor and outdoor amps.
- ‡ Chart data is for 80° F indoor dry bulb. For indoor db temperatures other than 80° F, measure Indoor db and Indoor CFM, and plug these into the formula below. Measure outdoor db and indoor wet bulb, apply these to the chart above, find MBh and S/T, and plug these into the formula below.
(Note: if indoor db is the only thing changing, total capacity, MBh, stays the same.)

Sensible Capacity at Indoor db LOWER than 80 °F = (MBh x S/T) - $\left(\frac{(80 - \text{Indoor db}) \times 835 \times \text{Indoor CFM}}{1000} \right)$

Sensible Capacity at Indoor db HIGHER than 80 °F = (MBh x S/T) + $\left(\frac{(\text{Indoor db} - 80) \times 835 \times \text{Indoor CFM}}{1000} \right)$

COOLING		30 Size Outdoor With ED*4X30B** Indoor Cooling																								
		Outdoor Ambient Temperature – Degrees F, Dry Bulb																								
		75					85					95					105					115				
		Entering Indoor Temperature – Degrees F, Wet Bulb																								
CFM		72	67	63††	62	57	72	67	63††	62	57	72	67	63††	62	57	72	67	63††	62	57	72	67	63††	62	57
875	MBh†	32.02	29.54	27.75	27.35	26.98	30.68	28.28	26.53	26.19	25.99	29.25	26.92	25.22	24.96	24.93	27.76	25.50	23.85	23.81	23.81	26.11	23.94	22.35	22.57	22.58
	S/T‡	0.51	0.69	0.72	0.89	1.00	0.52	0.70	0.73	0.91	1.00	0.53	0.72	0.75	0.99	1.00	0.53	0.74	0.76	1.00	1.00	0.55	0.76	0.79	1.00	1.00
	AMPS*	8.82	8.80	8.79	8.79	8.79	9.72	9.71	9.70	9.69	9.69	10.72	10.70	10.70	10.69	10.69	11.83	11.81	11.80	11.79	11.79	13.02	13.00	12.99	12.99	12.99
	HI PR	297	292	289	288	287	342	337	333	332	332	391	385	381	381	381	444	438	435	435	435	501	496	493	493	493
	LO PR	158	144	134	132	130	160	146	136	134	133	162	148	138	137	137	164	150	140	140	140	166	152	142	144	144
1000	MBh†	32.38	29.89	28.12	27.91	27.89	30.97	28.59	26.86	26.85	26.85	29.51	27.20	25.52	25.73	25.73	27.98	25.75	24.11	24.55	24.56	26.29	24.16	22.58	23.26	23.26
	S/T‡	0.53	0.73	0.75	0.99	1.00	0.54	0.74	0.77	1.00	1.00	0.55	0.76	0.78	1.00	1.00	0.56	0.78	0.81	1.00	1.00	0.57	0.81	0.83	1.00	1.00
	AMPS*	9.06	9.04	9.04	9.03	9.03	9.97	9.95	9.94	9.94	9.94	10.97	10.95	10.94	10.94	10.94	12.07	12.05	12.04	12.04	12.04	13.27	13.25	13.24	13.24	13.24
	HI PR	298	293	290	290	290	343	338	334	334	334	392	387	383	383	383	445	440	436	437	437	502	497	494	495	495
	LO PR	161	147	137	137	136	163	149	139	139	139	165	151	141	143	143	167	153	143	146	146	169	155	145	150	150
1125	MBh†	32.60	30.13	28.36	28.60	28.60	31.16	28.80	27.09	27.52	27.52	29.67	27.39	25.72	26.35	26.35	28.11	25.92	24.30	25.13	25.13	26.38	24.30	22.74	23.78	23.78
	S/T‡	0.55	0.76	0.78	1.00	1.00	0.56	0.78	0.80	1.00	1.00	0.57	0.80	0.82	1.00	1.00	0.58	0.83	0.85	1.00	1.00	0.60	0.85	0.88	1.00	1.00
	AMPS*	9.30	9.29	9.28	9.28	9.28	10.21	10.20	10.19	10.19	10.19	11.21	11.19	11.19	11.19	11.19	12.32	12.30	12.29	12.29	12.29	13.51	13.49	13.48	13.49	13.49
	HI PR	299	294	291	291	291	344	339	335	336	336	393	388	384	385	385	446	441	437	439	439	503	498	495	497	497
	LO PR	163	150	140	142	142	165	152	141	144	144	167	153	143	148	148	169	155	145	151	151	171	158	147	155	155

† Total capacities are net (I.D. blower heat subtracted) system capacities based on 25' line set.
 If additional tubing length and/or indoor unit is located above outdoor unit, a slight variation in capacity may occur.

†† At TVA rating indoor condition (75 °F db, 63 °F wb), all other indoor air temperatures are at 80 °F db
 If additional tubing length and/or indoor unit is located above outdoor unit, a slight variation in capacity may occur.

^ System amps are total of indoor and outdoor amps.

‡ Chart data is for 80° F indoor dry bulb. For indoor db temperatures other than 80° F, measure Indoor db and Indoor CFM, and plug these into the formula below. Measure outdoor db and indoor wet bulb, apply these to the chart above, find MBh and S/T, and plug these into the formula below.
 (Note: if indoor db is the only thing changing, total capacity, MBh, stays the same.)

$$\text{Sensible Capacity at Indoor db LOWER than } 80^\circ \text{ F} = (\text{MBh} \times \text{S/T}) - \left(\frac{(\text{80} - \text{Indoor db}) \times 835 \times \text{Indoor CFM}}{1000} \right)$$

$$\text{Sensible Capacity at Indoor db HIGHER than } 80^\circ \text{ F} = (\text{MBh} \times \text{S/T}) + \left(\frac{(\text{Indoor db} - 80) \times 835 \times \text{Indoor CFM}}{1000} \right)$$

COOLING		36 Size Outdoor With ED*4X36F** Indoor Cooling																								
		Outdoor Ambient Temperature – Degrees F, Dry Bulb																								
		75					85					95					105					115				
		Entering Indoor Temperature – Degrees F, Wet Bulb																								
CFM		72	67	63††	62	57	72	67	63††	62	57	72	67	63††	62	57	72	67	63††	62	57	72	67	63††	62	57
1050	MBh†	41.83	38.23	35.64	35.01	33.97	39.98	36.52	34.02	33.47	32.72	38.00	34.70	32.31	31.83	31.38	35.90	32.76	30.49	30.12	29.94	33.61	30.66	28.52	28.35	28.37
	S/T‡	0.51	0.69	0.72	0.89	1.00	0.52	0.70	0.73	0.91	1.00	0.53	0.72	0.74	0.93	1.00	0.54	0.73	0.76	0.96	1.00	0.55	0.76	0.78	1.00	1.00
	AMPS*	11.17	11.10	11.06	11.05	11.03	12.39	12.32	12.27	12.26	12.24	13.73	13.66	13.60	13.59	13.58	15.20	15.12	15.06	15.05	15.05	16.79	16.71	16.64	16.64	16.64
	HI PR	288	283	280	279	278	331	326	322	322	321	378	373	369	368	368	429	424	420	419	419	485	479	475	475	475
LO PR		152	139	130	128	124	154	141	132	130	127	157	144	134	132	131	159	146	136	135	135	162	149	139	139	139
1200	MBh†	42.52	38.89	36.27	35.78	35.32	40.59	37.10	34.58	34.21	33.99	38.53	35.20	32.80	32.58	32.55	36.35	33.20	30.92	31.02	31.02	33.98	31.03	28.90	29.34	29.34
	S/T‡	0.53	0.72	0.74	0.93	1.00	0.54	0.73	0.76	0.95	1.00	0.54	0.75	0.78	0.99	1.00	0.56	0.77	0.80	1.00	1.00	0.57	0.80	0.82	1.00	1.00
	AMPS*	11.43	11.36	11.31	11.31	11.30	12.64	12.58	12.53	12.52	12.52	13.99	13.91	13.86	13.86	13.86	15.45	15.38	15.32	15.33	15.33	17.04	16.96	16.91	16.92	16.92
	HI PR	289	284	281	280	280	332	327	324	323	323	379	374	370	370	370	431	425	421	421	421	486	480	476	477	477
LO PR		155	142	133	131	130	158	145	135	134	133	160	147	137	136	136	162	149	139	140	140	165	152	142	144	144
1350	MBh†	43.03	39.37	36.74	36.49	36.43	41.03	37.53	35.01	35.00	35.02	38.91	35.58	33.18	33.50	33.51	36.67	33.53	31.26	31.89	31.89	34.23	31.31	29.18	30.12	30.12
	S/T‡	0.54	0.75	0.77	0.97	1.00	0.55	0.76	0.79	1.00	1.00	0.56	0.78	0.81	1.00	1.00	0.57	0.81	0.83	1.00	1.00	0.59	0.84	0.86	1.00	1.00
	AMPS*	11.68	11.62	11.57	11.56	11.56	12.90	12.83	12.78	12.78	12.78	14.24	14.17	14.12	14.12	14.12	15.71	15.63	15.58	15.60	15.60	17.30	17.22	17.16	17.19	17.19
	HI PR	290	285	282	282	282	333	328	325	325	325	380	375	371	372	372	432	426	422	423	423	487	481	477	479	479
LO PR		158	145	135	135	135	160	147	137	138	138	162	149	139	141	141	165	151	141	145	145	167	154	144	149	149

- † Total capacities are net (I.D. blower heat subtracted) system capacities based on 25' line set.
If additional tubing length and/or indoor unit is located above outdoor unit, a slight variation in capacity may occur.
- †† At TVA rating indoor condition (75 °F db, 63 °F wb), all other indoor air temperatures are at 80 °F db
If additional tubing length and/or indoor unit is located above outdoor unit, a slight variation in capacity may occur.
- ^ System amps are total of indoor and outdoor amps.
- ‡ Chart data is for 80° F indoor dry bulb. For indoor db temperatures other than 80° F, measure Indoor db and Indoor CFM, and plug these into the formula below. Measure outdoor db and indoor wet bulb, apply these to the chart above, find MBh and S/T, and plug these into the formula below.
(Note: if indoor db is the only thing changing, total capacity, MBh, stays the same.)

Sensible Capacity at Indoor db LOWER than 80 °F = (MBh x S/T) - $\left(\frac{(80 - \text{Indoor db}) \times 835 \times \text{Indoor CFM}}{1000} \right)$

Sensible Capacity at Indoor db HIGHER than 80 °F = (MBh x S/T) + $\left(\frac{(\text{Indoor db} - 80) \times 835 \times \text{Indoor CFM}}{1000} \right)$

COOLING		42 Size Outdoor With ED*4X42J** Indoor Cooling																								
		Outdoor Ambient Temperature – Degrees F, Dry Bulb																								
		75					85					95					105					115				
CFM		Entering Indoor Temperature – Degrees F, Wet Bulb																								
		72	67	63††	62	57	72	67	63††	62	57	72	67	63††	62	57	72	67	63††	62	57	72	67	63††	62	57
1225	MBh†	48.49	44.47	41.53	40.83	39.73	46.39	42.52	39.69	39.07	38.29	44.18	40.46	37.74	37.22	36.76	41.83	38.28	35.68	35.29	35.12	39.28	35.93	33.47	33.32	33.34
	S/T‡	0.53	0.71	0.73	0.91	1.00	0.53	0.72	0.75	0.93	1.00	0.54	0.73	0.76	0.95	1.00	0.55	0.75	0.78	0.98	1.00	0.56	0.77	0.80	1.00	1.00
	AMPS*	14.73	14.49	14.32	14.28	14.22	16.22	15.97	15.80	15.77	15.72	17.86	17.61	17.44	17.41	17.38	19.67	19.43	19.25	19.23	19.22	21.64	21.40	21.23	21.22	21.23
	HI PR	279	275	272	271	270	323	318	315	314	314	370	365	362	361	361	421	416	413	412	412	475	471	467	467	467
	LO PR	151	139	129	127	124	154	141	131	129	127	156	143	133	132	130	158	145	135	134	134	161	148	138	138	138
1400	MBh†	49.21	45.16	42.22	41.69	41.25	47.02	43.14	40.31	39.91	39.72	44.73	41.00	38.28	38.02	38.08	42.30	38.75	36.17	36.34	36.34	39.67	36.34	33.89	34.45	34.45
	S/T‡	0.54	0.74	0.76	0.95	1.00	0.55	0.75	0.78	0.97	1.00	0.56	0.77	0.79	1.00	1.00	0.57	0.79	0.82	1.00	1.00	0.58	0.82	0.84	1.00	1.00
	AMPS*	15.11	14.86	14.68	14.66	14.63	16.59	16.34	16.16	16.14	16.13	18.22	17.97	17.80	17.78	17.79	20.03	19.79	19.61	19.63	19.63	22.00	21.76	21.59	21.63	21.63
	HI PR	280	276	273	272	272	324	319	316	316	315	371	366	363	363	363	422	417	414	414	414	476	472	468	469	469
	LO PR	155	142	132	131	129	157	144	134	133	132	159	146	136	135	136	161	148	138	139	139	164	151	140	143	143
1575	MBh†	49.75	45.69	42.75	42.52	42.49	47.50	43.61	40.79	40.87	40.87	45.14	41.42	38.72	39.14	39.15	42.64	39.12	36.55	37.31	37.32	39.94	36.65	34.23	35.32	35.32
	S/T‡	0.56	0.77	0.79	0.99	1.00	0.57	0.78	0.81	1.00	1.00	0.58	0.80	0.83	1.00	1.00	0.59	0.83	0.85	1.00	1.00	0.60	0.86	0.88	1.00	1.00
	AMPS*	15.47	15.22	15.04	15.03	15.03	16.94	16.70	16.52	16.53	16.53	18.58	18.33	18.15	18.19	18.19	20.39	20.14	19.97	20.02	20.02	22.35	22.11	21.94	22.02	22.02
	HI PR	281	277	274	273	273	325	320	317	317	317	372	367	364	364	364	423	418	415	416	416	477	472	469	471	471
	LO PR	157	144	134	134	134	159	146	136	137	137	161	148	138	140	140	164	150	140	144	144	166	153	143	148	148

† Total capacities are net (I.D. blower heat subtracted) system capacities based on 25' line set.
If additional tubing length and/or indoor unit is located above outdoor unit, a slight variation in capacity may occur.

†† At TVA rating indoor condition (75 °F db, 63 °F wb), all other indoor air temperatures are at 80 °F db
If additional tubing length and/or indoor unit is located above outdoor unit, a slight variation in capacity may occur.

^ System amps are total of indoor and outdoor amps.

‡ Chart data is for 80° F indoor dry bulb. For indoor db temperatures other than 80° F, measure Indoor db and Indoor CFM, and plug these into the formula below. Measure outdoor db and indoor wet bulb, apply these to the chart above, find MBh and S/T, and plug these into the formula below.
(Note: if indoor db is the only thing changing, total capacity, MBh, stays the same.)

$$\text{Sensible Capacity at Indoor db LOWER than } 80^\circ\text{F} = (\text{MBh} \times \text{S/T}) - \left(\frac{(\text{80} - \text{Indoor db}) \times 835 \times \text{Indoor CFM}}{1000} \right)$$

$$\text{Sensible Capacity at Indoor db HIGHER than } 80^\circ\text{F} = (\text{MBh} \times \text{S/T}) + \left(\frac{(\text{Indoor db} - 80) \times 835 \times \text{Indoor CFM}}{1000} \right)$$

COOLING		48 Size Outdoor With ED*4X48J** Indoor Cooling																								
		Outdoor Ambient Temperature – Degrees F, Dry Bulb																								
		75					85					95					105					115				
		Entering Indoor Temperature – Degrees F, Wet Bulb																								
CFM		72	67	63††	62	57	72	67	63††	62	57	72	67	63††	62	57	72	67	63††	62	57	72	67	63††	62	57
1400	MBh†	54.48	49.80	46.41	45.58	44.55	52.18	47.63	44.36	43.61	42.94	49.73	45.34	42.19	41.55	41.23	47.13	42.93	39.89	39.45	39.42	44.34	40.34	37.46	37.47	37.47
	S/T‡	0.48	0.65	0.68	0.85	1.00	0.49	0.67	0.69	0.87	1.00	0.50	0.68	0.71	0.89	1.00	0.51	0.70	0.72	0.99	1.00	0.52	0.72	0.75	1.00	1.00
	AMPS*	14.71	14.60	14.52	14.50	14.48	16.25	16.13	16.06	16.04	16.03	17.94	17.83	17.76	17.74	17.74	19.82	19.71	19.65	19.63	19.63	21.88	21.78	21.72	21.72	21.72
	HI PR	296	292	289	288	287	342	338	334	334	333	392	387	384	383	383	447	442	439	438	438	507	502	499	499	499
	LO PR	154	141	131	129	126	156	143	133	131	129	158	145	135	134	133	161	147	137	136	136	163	150	140	140	140
1600	MBh†	55.34	50.62	47.22	46.58	46.27	52.95	48.38	45.08	44.61	44.56	50.42	46.00	42.83	42.74	42.75	47.73	43.51	40.47	40.82	40.82	44.84	40.84	37.96	38.75	38.75
	S/T‡	0.50	0.68	0.71	0.89	1.00	0.51	0.70	0.72	0.99	1.00	0.52	0.71	0.74	1.00	1.00	0.53	0.73	0.76	1.00	1.00	0.54	0.76	0.79	1.00	1.00
	AMPS*	15.07	14.95	14.88	14.86	14.85	16.60	16.49	16.41	16.40	16.40	18.30	18.18	18.11	18.11	18.11	20.17	20.06	20.00	20.00	20.00	22.23	22.13	22.07	22.08	22.08
	HI PR	297	293	290	289	289	343	339	335	335	335	393	388	385	385	385	448	443	440	440	440	508	503	500	501	501
	LO PR	157	144	134	133	132	159	146	136	135	135	161	148	138	138	138	163	150	140	142	142	166	152	142	145	145
1800	MBh†	55.96	51.21	47.80	47.66	47.67	53.51	48.91	45.61	45.87	45.88	50.90	46.48	43.31	43.97	43.97	48.15	43.93	40.89	41.94	41.95	45.18	41.20	38.33	39.77	39.77
	S/T‡	0.52	0.71	0.74	1.00	1.00	0.52	0.73	0.75	1.00	1.00	0.53	0.75	0.77	1.00	1.00	0.55	0.77	0.80	1.00	1.00	0.56	0.80	0.82	1.00	1.00
	AMPS*	15.43	15.30	15.23	15.22	15.22	16.96	16.84	16.76	16.76	16.76	18.65	18.53	18.46	18.47	18.47	20.53	20.41	20.34	20.36	20.36	22.58	22.47	22.42	22.44	22.44
	HI PR	298	294	291	291	291	344	339	336	336	336	394	389	386	387	387	449	444	441	442	442	509	504	501	502	502
	LO PR	160	147	137	137	137	162	148	138	140	140	164	150	140	143	143	166	152	142	146	146	168	155	144	150	150

- † Total capacities are net (I.D. blower heat subtracted) system capacities based on 25' line set.
If additional tubing length and/or indoor unit is located above outdoor unit, a slight variation in capacity may occur.
- †† At TVA rating indoor condition (75 °F db, 63 °F wb), all other indoor air temperatures are at 80 °F db
If additional tubing length and/or indoor unit is located above outdoor unit, a slight variation in capacity may occur.
- ^ System amps are total of indoor and outdoor amps.
- ‡ Chart data is for 80° F indoor dry bulb. For indoor db temperatures other than 80° F, measure Indoor db and Indoor CFM, and plug these into the formula below. Measure outdoor db and indoor wet bulb, apply these to the chart above, find MBh and S/T, and plug these into the formula below.
(Note: if indoor db is the only thing changing, total capacity, MBh, stays the same.)

Sensible Capacity at Indoor db LOWER than 80 °F = (MBh x S/T) - $\left(\frac{ (80 - \text{Indoor db}) \times 835 \times \text{Indoor CFM} }{ 1000 } \right)$

Sensible Capacity at Indoor db HIGHER than 80 °F = (MBh x S/T) + $\left(\frac{ (\text{Indoor db} - 80) \times 835 \times \text{Indoor CFM} }{ 1000 } \right)$

COOLING		60 Size Outdoor With ED*4X60L** Indoor Cooling																								
		Outdoor Ambient Temperature – Degrees F, Dry Bulb																								
		75					85					95					105					115				
		Entering Indoor Temperature – Degrees F, Wet Bulb																								
CFM		72	67	62	57	72	67	62	57	72	67	62	57	72	67	62	57	72	67	62	57					
1750	MBh†	67.21	61.78	56.85	55.51	64.33	59.11	54.44	53.53	61.25	56.26	51.89	51.41	57.99	53.27	49.28	49.17	54.51	50.10	46.74	46.74					
	S/T‡	0.51	0.68	0.88	1.00	0.51	0.69	0.90	1.00	0.52	0.71	0.92	1.00	0.53	0.73	0.94	1.00	0.54	0.75	1.00	1.00					
	AMPS *	18.11	17.91	17.74	17.69	20.10	19.90	19.72	19.69	22.29	22.09	21.91	21.90	24.72	24.53	24.37	24.36	27.38	27.21	27.07	27.07					
	HI PR	304	299	294	293	350	345	340	339	401	394	389	388	455	449	443	443	514	507	502	502					
	LO PR	155	142	130	127	157	144	132	130	160	146	134	133	162	148	137	137	164	151	141	141					
2000	MBh†	68.22	62.74	58.02	57.57	65.20	59.96	55.58	55.46	62.01	57.00	53.19	53.20	58.62	53.90	50.79	50.80	55.02	50.62	48.19	48.19					
	S/T‡	0.52	0.71	0.92	1.00	0.53	0.73	0.94	1.00	0.54	0.75	1.00	1.00	0.55	0.77	1.00	1.00	0.56	0.79	1.00	1.00					
	AMPS *	18.57	18.36	18.19	18.17	20.55	20.34	20.17	20.17	22.74	22.53	22.38	22.38	25.16	24.96	24.84	24.84	27.82	27.64	27.54	27.54					
	HI PR	305	300	295	295	352	346	341	341	402	396	391	391	456	450	446	446	515	509	505	505					
	LO PR	159	145	134	133	161	147	136	136	163	149	139	139	165	151	142	142	167	154	146	146					
2250	MBh†	68.93	63.43	59.25	59.25	65.81	60.56	57.01	57.01	62.53	57.53	54.62	54.62	59.04	54.34	52.11	52.12	55.34	50.99	49.36	49.36					
	S/T‡	0.54	0.74	1.00	1.00	0.55	0.76	1.00	1.00	0.56	0.78	1.00	1.00	0.57	0.81	1.00	1.00	0.59	0.83	1.00	1.00					
	AMPS *	19.00	18.80	18.65	18.64	20.98	20.78	20.64	20.64	23.17	22.96	22.85	22.85	25.59	25.39	25.31	25.31	28.24	28.07	28.01	28.01					
	HI PR	306	301	297	297	353	347	343	343	403	397	393	393	458	451	448	448	516	510	507	507					
	LO PR	162	148	138	138	163	150	141	141	165	152	144	144	167	154	147	147	169	156	151	151					

† Total capacities are net (I.D. blower heat subtracted) system capacities based on 25' line set.
 If additional tubing length and/or indoor unit is located above outdoor unit, a slight variation in capacity may occur.

†† At TVA rating indoor condition (75 °F db, 63 °F wb), all other indoor air temperatures are at 80 °F db
 If additional tubing length and/or indoor unit is located above outdoor unit, a slight variation in capacity may occur.

^ System amps are total of indoor and outdoor amps.

‡ Chart data is for 80° F indoor dry bulb. For indoor db temperatures other than 80° F, measure Indoor db and Indoor CFM, and plug these into the formula below. Measure outdoor db and indoor wet bulb, apply these to the chart above, find MBh and S/T, and plug these into the formula below.
 (Note: if indoor db is the only thing changing, total capacity, MBh, stays the same.)

$$\text{Sensible Capacity at Indoor db LOWER than } 80^\circ \text{ F} = (\text{MBh} \times \text{S/T}) - \left(\frac{(\text{80} - \text{Indoor db}) \times 835 \times \text{Indoor CFM}}{1000} \right)$$

$$\text{Sensible Capacity at Indoor db HIGHER than } 80^\circ \text{ F} = (\text{MBh} \times \text{S/T}) + \left(\frac{(\text{Indoor db} - 80) \times 835 \times \text{Indoor CFM}}{1000} \right)$$

Data for Condenser Only (Cooling)									
Saturated Suction Temperature °F		Condenser Entering Air Temperature °F							
		55	65	75	85	95	105	115	125
(C,H,T)4A318									
30	TCG	16.10	15.20	14.20	13.30	12.30	11.30	10.20	9.10
	SDT	70.80	80.40	89.90	99.50	109.10	118.80	128.60	138.50
	KW	0.83	0.95	1.09	1.24	1.40	1.57	1.76	1.95
35	TCG	17.70	16.70	15.70	14.70	13.70	12.60	11.50	10.30
	SDT	71.90	81.40	90.90	100.40	109.90	119.60	129.40	139.10
	KW	0.83	0.95	1.09	1.24	1.40	1.58	1.77	1.97
40	TCG	19.50	18.40	17.40	16.20	15.10	14.00	12.80	11.50
	SDT	73.00	82.50	91.90	101.30	110.80	120.40	130.10	139.70
	KW	0.83	0.95	1.09	1.23	1.40	1.58	1.77	1.98
45	TCG	21.30	20.20	19.00	17.90	16.70	15.40	14.20	12.80
	SDT	74.20	83.60	93.00	102.30	111.70	121.20	130.70	140.30
	KW	0.83	0.95	1.08	1.23	1.40	1.58	1.78	1.99
50	TCG	23.30	22.00	20.80	19.50	18.20	16.90	15.60	14.20
	SDT	75.40	84.80	94.10	103.40	112.60	122.00	131.40	140.90
	KW	0.82	0.95	1.08	1.23	1.40	1.58	1.78	1.99
55	TCG	25.20	23.90	22.50	21.20	19.80	18.50	17.00	15.50
	SDT	76.70	86.00	95.20	104.40	113.60	122.90	132.20	141.50
	KW	0.82	0.94	1.08	1.23	1.39	1.58	1.78	1.99
(C,H,T)4A324									
30	TCG	21.30	20.10	18.90	17.70	16.50	15.20	14.00	12.60
	SDT	73.00	82.40	91.80	101.20	110.60	120.20	129.80	139.40
	KW	1.06	1.21	1.37	1.56	1.77	1.99	2.24	2.51
35	TCG	23.40	22.10	20.90	19.60	18.20	16.90	15.50	14.10
	SDT	74.40	83.60	93.00	102.30	111.70	121.10	130.60	140.20
	KW	1.06	1.21	1.38	1.57	1.77	2.00	2.25	2.52
40	TCG	25.60	24.20	22.90	21.50	20.00	18.60	17.10	15.60
	SDT	75.80	85.00	94.20	103.50	112.70	122.10	131.50	140.90
	KW	1.07	1.22	1.39	1.58	1.78	2.01	2.26	2.53
45	TCG	27.90	26.40	24.90	23.40	21.90	20.40	18.80	17.10
	SDT	77.30	86.30	95.50	104.70	113.80	123.10	132.30	141.60
	KW	1.08	1.23	1.40	1.58	1.79	2.02	2.27	2.54
50	TCG	30.20	28.60	27.00	25.40	23.70	22.10	20.40	18.60
	SDT	78.80	87.80	96.80	105.90	114.90	124.10	133.30	142.40
	KW	1.09	1.24	1.40	1.59	1.80	2.03	2.28	2.55
55	TCG	32.60	30.80	29.10	27.30	25.60	23.90	22.10	20.20
	SDT	80.30	89.20	98.20	107.10	116.10	125.20	134.20	143.10
	KW	1.09	1.25	1.41	1.60	1.81	2.03	2.28	2.55

TCG = Gross Cooling Capacity (x 1000 BTU/hr)
 SDT = Saturated Temperature Leaving Compressor
 kW = Outdoor Unit Kilowatts

Data for Condenser Only (Cooling)									
Saturated Suction Temperature °F		Condenser Entering Air Temperature °F							
		55	65	75	85	95	105	115	125
(C,H,T)4A330									
30	TCG	25.40	24.00	22.60	21.10	19.60	18.00	16.40	14.60
	SDT	74.40	83.60	92.90	102.10	111.40	120.80	130.20	139.60
	KW	1.35	1.52	1.70	1.91	2.13	2.37	2.63	2.89
35	TCG	28.00	26.50	24.90	23.40	21.70	20.00	18.30	16.40
	SDT	75.90	85.00	94.20	103.40	112.60	121.90	131.20	140.50
	KW	1.35	1.52	1.71	1.92	2.15	2.39	2.65	2.92
40	TCG	30.70	29.10	27.40	25.70	24.00	22.20	20.30	18.40
	SDT	77.40	86.50	95.60	104.70	113.80	123.00	132.20	141.40
	KW	1.35	1.53	1.72	1.93	2.15	2.40	2.67	2.95
45	TCG	33.50	31.80	30.00	28.20	26.30	24.40	22.40	20.30
	SDT	79.00	88.00	97.00	106.10	115.10	124.20	133.30	142.30
	KW	1.36	1.53	1.72	1.93	2.16	2.42	2.69	2.97
50	TCG	36.50	34.60	32.70	30.70	28.70	26.70	24.60	22.30
	SDT	80.70	89.70	98.50	107.50	116.40	125.40	134.30	143.20
	KW	1.36	1.54	1.73	1.94	2.17	2.43	2.70	2.99
55	TCG	39.50	37.40	35.30	33.20	31.10	29.00	26.70	24.30
	SDT	82.40	91.30	100.10	108.90	117.80	126.60	135.40	144.20
	KW	1.37	1.54	1.74	1.95	2.18	2.44	2.71	3.00
(C,H,T)4A336									
30	TCG	32.60	30.90	29.10	27.20	25.30	23.30	21.20	19.00
	SDT	71.10	80.30	89.70	99.00	108.30	117.60	126.90	136.10
	KW	1.66	1.88	2.13	2.40	2.69	3.00	3.34	3.68
35	TCG	35.90	34.00	32.10	30.10	28.00	25.90	23.60	21.30
	SDT	72.40	81.70	90.90	100.20	109.40	118.70	127.90	137.00
	KW	1.68	1.90	2.14	2.41	2.71	3.03	3.37	3.73
40	TCG	39.40	37.40	35.30	33.10	30.90	28.60	26.20	23.60
	SDT	73.90	83.00	92.20	101.40	110.60	119.70	128.90	137.90
	KW	1.69	1.91	2.16	2.43	2.73	3.05	3.40	3.77
45	TCG	43.20	40.90	38.70	36.40	34.00	31.50	28.90	26.10
	SDT	75.40	84.50	93.60	102.70	111.80	120.90	129.90	138.80
	KW	1.70	1.92	2.17	2.45	2.75	3.07	3.42	3.80
50	TCG	47.10	44.70	42.20	39.70	37.10	34.40	31.60	28.60
	SDT	76.90	86.00	95.00	104.00	113.00	122.00	131.00	139.80
	KW	1.72	1.94	2.19	2.46	2.76	3.09	3.45	3.82
55	TCG	51.20	48.60	46.00	43.20	40.40	37.50	34.40	31.10
	SDT	78.60	87.60	96.50	105.40	114.40	123.30	132.10	140.70
	KW	1.74	1.96	2.21	2.48	2.78	3.11	3.47	3.85

TCG = Gross Cooling Capacity (x 1000 BTU/hr)
 SDT = Saturated Temperature Leaving Compressor
 kW = Outdoor Unit Kilowatts

Data for Condenser Only (Cooling)									
Saturated Suction Temperature °F		Condenser Entering Air Temperature °F							
		55	65	75	85	95	105	115	125
(C,H,T)4A342									
30	TCG	38.00	36.00	33.90	31.90	29.70	27.60	25.30	22.90
	SDT	73.20	82.30	91.40	100.60	109.80	119.10	128.40	137.70
	KW	1.95	2.20	2.48	2.80	3.14	3.53	3.95	4.41
35	TCG	41.90	39.70	37.40	35.10	32.80	30.50	28.00	25.50
	SDT	74.80	83.70	92.80	101.90	111.00	120.20	129.40	138.60
	KW	1.97	2.22	2.50	2.81	3.16	3.54	3.97	4.43
40	TCG	46.00	43.60	41.10	38.70	36.20	33.60	30.90	28.10
	SDT	76.40	85.20	94.20	103.20	112.20	121.30	130.40	139.50
	KW	1.98	2.23	2.52	2.83	3.18	3.56	3.98	4.44
45	TCG	50.30	47.70	45.10	42.40	39.60	36.80	33.90	30.90
	SDT	78.10	86.90	95.70	104.60	113.50	122.50	131.40	140.40
	KW	2.01	2.26	2.54	2.85	3.19	3.58	4.00	4.45
50	TCG	54.90	52.10	49.20	46.20	43.20	40.20	37.00	33.60
	SDT	80.00	88.60	97.20	106.00	114.80	123.70	132.50	141.30
	KW	2.03	2.28	2.56	2.87	3.21	3.60	4.01	4.47
55	TCG	59.70	56.60	53.40	50.20	46.90	43.50	40.10	36.40
	SDT	81.90	90.30	98.90	107.50	116.20	124.90	133.60	142.20
	KW	2.06	2.30	2.58	2.89	3.23	3.62	4.03	4.48
(C,H,T)4A348									
30	TCG	41.10	38.90	36.70	34.40	32.10	29.70	27.20	24.50
	SDT	73.80	83.00	92.30	101.60	111.00	120.40	129.70	139.10
	KW	2.19	2.46	2.76	3.10	3.47	3.87	4.30	4.76
35	TCG	45.20	42.80	40.50	38.00	35.50	32.90	30.20	27.40
	SDT	75.30	84.40	93.70	102.90	112.20	121.50	130.80	140.00
	KW	2.22	2.49	2.79	3.13	3.50	3.90	4.34	4.81
40	TCG	49.60	47.10	44.50	41.90	39.20	36.40	33.50	30.40
	SDT	76.90	86.00	95.10	104.30	113.40	122.60	131.80	141.00
	KW	2.24	2.51	2.82	3.15	3.53	3.93	4.38	4.85
45	TCG	54.30	51.60	48.80	46.00	43.10	40.10	36.90	33.60
	SDT	78.50	87.50	96.60	105.70	114.70	123.80	132.90	142.00
	KW	2.27	2.54	2.85	3.19	3.56	3.97	4.41	4.89
50	TCG	59.30	56.40	53.40	50.30	47.10	43.90	40.50	36.90
	SDT	80.20	89.20	98.10	107.10	116.10	125.10	134.10	143.00
	KW	2.30	2.58	2.88	3.22	3.59	4.00	4.45	4.92
55	TCG	64.60	61.40	58.10	54.80	51.40	47.90	44.20	40.30
	SDT	82.10	91.00	99.80	108.70	117.50	126.40	135.20	144.00
	KW	2.34	2.61	2.92	3.25	3.63	4.04	4.48	4.96

TCG = Gross Cooling Capacity (x 1000 BTU/hr)

SDT = Saturated Temperature Leaving Compressor

kW = Outdoor Unit Kilowatts

Data for Condenser Only (Cooling)									
Saturated Suction Temperature °F		Condenser Entering Air Temperature °F							
		55	65	75	85	95	105	115	125
(C,H,T)4A360									
30	TCG	54.90	51.90	49.00	46.00	42.90	39.80	36.50	33.10
	SDT	77.60	86.40	95.30	104.20	113.20	122.20	131.20	140.20
	KW	2.73	3.07	3.45	3.88	4.34	4.85	5.41	6.01
35	TCG	60.30	57.10	53.90	50.70	47.30	43.90	40.30	36.50
	SDT	79.50	88.20	97.00	105.80	114.70	123.60	132.50	141.30
	KW	2.79	3.13	3.51	3.94	4.40	4.92	5.48	6.08
40	TCG	66.00	62.60	59.10	55.50	51.90	48.20	44.30	40.10
	SDT	81.60	90.20	98.80	107.50	116.30	125.00	133.80	142.50
	KW	2.86	3.20	3.58	4.00	4.47	4.98	5.54	6.15
45	TCG	72.10	68.30	64.50	60.70	56.70	52.60	48.40	43.80
	SDT	83.80	92.20	100.70	109.30	117.90	126.50	135.10	143.60
	KW	2.93	3.27	3.65	4.08	4.54	5.06	5.61	6.21
50	TCG	78.50	74.40	70.20	66.00	61.60	57.20	52.50	47.50
	SDT	86.10	94.40	102.70	111.20	119.60	128.10	136.50	144.80
	KW	3.01	3.35	3.73	4.15	4.62	5.13	5.68	6.27
55	TCG	85.10	80.60	76.10	71.40	66.70	61.80	56.70	51.20
	SDT	88.60	96.60	104.80	113.10	121.40	129.70	137.90	146.00
	KW	3.09	3.44	3.81	4.24	4.70	5.21	5.75	6.34

TCG = Gross Cooling Capacity (x 1000 BTU/hr)

SDT = Saturated Temperature Leaving Compressor

kW = Outdoor Unit Kilowatts

COOLING Multiplying Factors for other Indoor Combinations

Indoor Model	Furnace Model	Capac. (MBh)	Power (AMPS)	Indoor Model	Furnace Model	Capac. (MBh)	Power (AMPS)	Indoor Model	Furnace Model	Capac. (MBh)	Power (AMPS)
(C,H,T)4A318											
>ED*4X18B**		1.00	1.00	ED*4X24F**		1.00	1.00	EMA4X24D**		1.00	1.00
ED*4X18B**	*8MPV050	1.05	0.95	EHD4X24A**	*8MPV050	1.00	0.89	FEM4X18****		1.00	0.91
ED*4X18B**	MV08B15**B*	1.00	0.89	EHD4X24A**	*9MPV050	1.00	0.89	FEM4X24****		1.00	0.89
ED*4X24B**	*8MPV050	1.07	0.96	EHD4X24A**	*9MPV075	1.00	0.91	FS(M,U)4X18***		1.00	1.00
ED*4X24B**	MV08B15**B*	1.00	0.89	EHD4X24A**	*9MVX040	1.05	0.95	FS(M,U)4X24*** *		1.05	1.05
ED*4X24B**		1.00	1.00	EHD4X24A**	*9MVX060	1.05	0.95	FSA4X18**A*		1.00	1.00
ED*4X24F**	*9MPV050	1.07	0.96	EHD4X24A**	MV08B15**B*	1.00	0.89	FSA4X24**A*		1.00	1.00
ED*4X24F**	*9MPV075	1.08	0.96	EHD4X24A**		1.00	1.00	FVM4X24****		1.00	0.89
(C,H,T)4A324											
>ED*4X24B**		1.00	1.00	EHD4X24A**	*8MPV050	0.99	0.93	EHD4X30A**	*9MPV075	1.00	0.94
ED*4X24B**	*8MPV050	0.99	0.93	EHD4X24A**	*8MPV075	1.00	0.94	EHD4X30A**	*9MPV100	1.00	0.92
ED*4X24B**	MV08B15**B*	1.00	0.90	EHD4X24A**	*8MPV100	1.00	0.92	EHD4X30A**	*9MPV125	1.00	0.92
ED*4X24F**	*8MPV075	1.00	0.92	EHD4X24A**	*8MPV125	1.00	0.92	EHD4X30A**	*9MVX040	1.02	0.96
ED*4X24F**	*9MPV050	0.99	0.93	EHD4X24A**	*9MPV050	0.99	0.93	EHD4X30A**	*9MVX060	1.02	0.93
ED*4X24F**	*9MPV075	1.00	0.94	EHD4X24A**	*9MPV075	1.00	0.94	EHD4X30A**	*9MVX080	1.02	0.93
ED*4X24F**	*9MVX040	1.00	0.94	EHD4X24A**	*9MPV100	1.00	0.96	EHD4X30A**	*9MVX100	1.02	0.92
ED*4X24F**	*9MVX060	1.01	0.95	EHD4X24A**	*9MPV125	1.00	0.92	EHD4X30A**	MV08B15**B*	1.00	0.90
ED*4X24F**	MV12F19**B*	1.00	0.90	EHD4X24A**	*9MVX040	1.00	0.94	EHD4X30A**	MV12F19**B*	1.00	0.90
ED*4X24F**		1.00	1.00	EHD4X24A**	*9MVX060	1.01	0.95	EHD4X30A**		1.00	1.00
ED*4X30B**	*8MPV050	1.00	0.92	EHD4X24A**	*9MVX080	1.01	0.92	EMA4X24D**		1.00	1.00
ED*4X30B**	MV08B15**B*	1.00	0.90	EHD4X24A**	*9MVX100	1.01	0.92	FEM4X24****		1.00	0.94
ED*4X30B**		1.00	1.00	EHD4X24A**	MV08B15**B*	1.00	0.90	FEM4X30****		1.00	0.92
ED*4X30F**	*8MPV075	1.00	0.92	EHD4X24A**	MV12F19**B*	1.00	0.90	FS(M,U)4X24***		0.99	0.99

> Indicates Tested Indoor Model

- continued on next page -

COOLING Multiplying Factors for other Indoor Combinations (continued)											
Indoor Model	Furnace Model	Capac. (MBh)	Power (AMPS)	Indoor Model	Furnace Model	Capac. (MBh)	Power (AMPS)	Indoor Model	Furnace Model	Capac. (MBh)	Power (AMPS)
ED*4X30F**	*9MPV050	1.00	0.92	EHD4X24A**		1.00	1.00	FS(M,U)4X30***		1.00	1.00
ED*4X30F**	*9MPV075	1.00	0.94	EHD4X30A**	*8MPV050	1.00	0.92	FSA4X24**A*		0.98	0.99
ED*4X30F**	*9MVX040	1.02	0.93	EHD4X30A**	*8MPV075	1.00	0.92	FSA4X30**A*		1.00	1.01
ED*4X30F**	*9MVX060	1.02	0.93	EHD4X30A**	*8MPV100	1.00	0.90	FVM4X24****		0.98	0.90
ED*4X30F**	MV12F19**B*	1.00	0.90	EHD4X30A**	*8MPV125	1.00	0.90	FVM4X36****		1.00	0.90
ED*4X30F**		1.00	1.00	EHD4X30A**	*9MPV050	1.00	0.94				
(C,H,T)4A330											
>ED*4X30B**		1.00	1.00	ED*4X36J**	*9MPV100	1.00	0.92	EHD4X36A**	*9MPV050	1.00	0.94
ED*4X30B**	*8MPV050	1.00	0.98	ED*4X36J**	*9MVX080	1.02	0.94	EHD4X36A**	*9MPV075	1.00	0.94
ED*4X30B**	MV08B15**B*	1.00	0.90	ED*4X36J**		1.00	1.00	EHD4X36A**	*9MPV100	1.00	0.92
ED*4X30F**	*8MPV075	1.00	0.92	EHD4X30A**	*8MPV050	1.00	0.98	EHD4X36A**	*9MPV125	1.00	0.90
ED*4X30F**	*9MPV050	1.00	0.96	EHD4X30A**	*8MPV075	1.00	0.94	EHD4X36A**	*9MVX040	1.01	0.97
ED*4X30F**	*9MPV075	1.00	0.96	EHD4X30A**	*8MPV100	1.00	0.92	EHD4X36A**	*9MVX060	1.01	0.95
ED*4X30F**	*9MVX040	1.01	0.97	EHD4X30A**	*8MPV125	1.00	0.92	EHD4X36A**	*9MVX080	1.02	0.94
ED*4X30F**	*9MVX060	1.01	0.95	EHD4X30A**	*9MPV050	1.00	0.96	EHD4X36A**	*9MVX100	1.02	0.92
ED*4X30F**	MV12F19**B*	1.00	0.89	EHD4X30A**	*9MPV075	1.00	0.96	EHD4X36A**	MV08B15**B*	1.00	0.90
ED*4X30F**		1.00	1.00	EHD4X30A**	*9MPV100	1.00	0.92	EHD4X36A**	MV12F19**B*	1.00	0.89
ED*4X36B**	*8MPV050	1.00	0.98	EHD4X30A**	*9MPV125	1.00	0.92	EHD4X36A**		1.00	1.00
ED*4X36B**	MV08B15**B*	1.00	0.90	EHD4X30A**	*9MVX040	1.01	0.97	EMA4X36D**		1.00	1.00
ED*4X36B**		1.00	1.00	EHD4X30A**	*9MVX060	1.01	0.95	FEM4X30****		1.00	0.94
ED*4X36F**	*8MPV075	1.00	0.92	EHD4X30A**	*9MVX080	1.01	0.93	FEM4X36****		1.00	0.94
ED*4X36F**	*9MPV050	1.00	0.96	EHD4X30A**	*9MVX100	1.01	0.93	FS(M,U)4X30***		0.99	0.99
ED*4X36F**	*9MPV075	1.00	0.94	EHD4X30A**	MV08B15**B*	1.00	0.90	FSA4X36**A*		1.00	1.00
ED*4X36F**	*9MVX040	1.01	0.97	EHD4X30A**	MV12F19**B*	1.00	0.90	FSM4X36****		1.00	1.00

> Indicates Tested Indoor Model

- continued on next page -

COOLING Multiplying Factors for other Indoor Combinations (continued)

Indoor Model	Furnace Model	Capac. (MBh)	Power (AMPS)	Indoor Model	Furnace Model	Capac. (MBh)	Power (AMPS)	Indoor Model	Furnace Model	Capac. (MBh)	Power (AMPS)
ED*4X36F**	*9MVX060	1.01	0.95	EHD4X30A**		1.00	1.00	FVM4X24****		0.99	0.91
ED*4X36F**	MV12F19**B*	1.00	0.89	EHD4X36A**	*8MPV050	1.00	0.98	FVM4X36****		1.00	0.89
ED*4X36F**		1.00	1.00	EHD4X36A**	*8MPV075	1.00	0.92	FVM4X48****		1.00	0.89
ED*4X36J**	*8MPV100	1.00	0.90	EHD4X36A**	*8MPV100	1.00	0.90				
ED*4X36J**	*8MPV125	1.00	0.90	EHD4X36A**	*8MPV125	1.00	0.90				
(C,H,T)4A336											
>ED*4X36F**		1.00	1.00	ED*4X42J**	*9MVX080	1.00	0.94	EHD4X42A**	*8MPV100	1.00	0.92
ED*4X36B**	*8MPV050	0.97	0.97	ED*4X42J**	MV16J22**B*	1.00	0.90	EHD4X42A**	*8MPV125	1.00	0.92
ED*4X36B**	MV08B15**B*	0.98	0.92	ED*4X42J**		1.00	1.00	EHD4X42A**	*9MPV050	1.00	0.98
ED*4X36B**		0.97	0.97	ED*4X42L**	*9MPV125	1.00	0.92	EHD4X42A**	*9MPV075	1.00	0.98
ED*4X36F**	*8MPV075	1.00	0.96	ED*4X42L**	*9MVX100	1.00	0.92	EHD4X42A**	*9MPV100	1.00	0.94
ED*4X36F**	*9MPV050	0.99	0.98	ED*4X42L**	MV20L24**B*	1.00	0.90	EHD4X42A**	*9MPV125	1.00	0.92
ED*4X36F**	*9MPV075	1.00	0.98	ED*4X42L**		1.00	1.00	EHD4X42A**	*9MVX040	1.00	0.98
ED*4X36F**	*9MVX040	0.99	0.99	EHD4X36A**	*8MPV050	1.00	1.00	EHD4X42A**	*9MVX060	1.00	0.96
ED*4X36F**	*9MVX060	1.00	0.98	EHD4X36A**	*8MPV075	1.00	0.96	EHD4X42A**	*9MVX080	1.00	0.94
ED*4X36F**	MV12F19**B*	1.00	0.92	EHD4X36A**	*8MPV100	1.00	0.94	EHD4X42A**	*9MVX100	1.00	0.92
ED*4X36J**	*8MPV100	1.00	0.94	EHD4X36A**	*8MPV125	1.00	0.92	EHD4X42A**	MV08B15**B*	1.00	0.90
ED*4X36J**	*8MPV125	1.00	0.92	EHD4X36A**	*9MPV050	1.00	0.98	EHD4X42A**	MV12F19**B*	1.00	0.90
ED*4X36J**	*9MPV100	1.00	0.94	EHD4X36A**	*9MPV075	1.00	0.98	EHD4X42A**	MV16J22**B*	1.00	0.90
ED*4X36J**	*9MVX080	1.00	0.94	EHD4X36A**	*9MPV100	1.00	0.94	EHD4X42A**	MV20L24**B*	1.00	0.90
ED*4X36J**	MV16J22**B*	1.00	0.90	EHD4X36A**	*9MPV125	1.00	0.92	EHD4X42A**		1.00	1.00
ED*4X36J**		1.00	1.00	EHD4X36A**	*9MVX040	0.99	0.99	EMA4X36D**		1.00	1.00
ED*4X42F**	*8MPV075	0.99	0.93	EHD4X36A**	*9MVX060	1.00	0.98	FEM4X36****		1.00	0.94
ED*4X42F**	*9MPV050	0.98	0.96	EHD4X36A**	*9MVX080	1.00	0.94	FEM4X42****		1.00	0.94
ED*4X42F**	*9MPV075	0.98	0.97	EHD4X36A**	*9MVX100	1.00	0.92	FS(M,U)4X42***		1.00	1.00

> Indicates Tested Indoor Model

- continued on next page -

COOLING Multiplying Factors for other Indoor Combinations (continued)											
Indoor Model	Furnace Model	Capac. (MBh)	Power (AMPS)	Indoor Model	Furnace Model	Capac. (MBh)	Power (AMPS)	Indoor Model	Furnace Model	Capac. (MBh)	Power (AMPS)
ED*4X42F**	*9MVX040	1.00	0.98	EHD4X36A**	MV08B15**B*	1.00	0.94	FSA4X36**A*		1.00	1.02
ED*4X42F**	*9MVX060	1.00	0.96	EHD4X36A**	MV12F19**B*	1.00	0.92	FSM4X36****		1.00	1.00
ED*4X42F**	MV12F19**B*	0.99	0.90	EHD4X36A**	MV16J22**B*	1.00	0.90	FSU4X36****		1.00	1.02
ED*4X42F**		0.99	0.99	EHD4X36A**	MV20L24**B*	1.00	0.90	FVM4X24****		1.00	0.94
ED*4X42J**	*8MPV100	1.00	0.92	EHD4X36A**		1.00	1.00	FVM4X36****		1.00	0.92
ED*4X42J**	*8MPV125	1.00	0.92	EHD4X42A**	*8MPV050	1.00	0.98	FVM4X48****		1.00	0.90
ED*4X42J**	*9MPV100	1.00	0.94	EHD4X42A**	*8MPV075	1.00	0.94	FVM4X60****		1.00	0.88
(C,H,T)4A342											
>ED*4X42J**		1.00	1.00	ED*4X48J**	*9MVX080	1.00	0.94	EHD4X48A**	*8MPV075	1.01	0.99
ED*4X42F**	*8MPV075	0.98	0.96	ED*4X48J**	MV16J22**B*	1.00	0.90	EHD4X48A**	*8MPV100	1.00	0.94
ED*4X42F**	*9MPV075	0.98	0.98	ED*4X48J**		1.00	0.98	EHD4X48A**	*9MPV075	1.00	0.98
ED*4X42F**	*9MVX060	0.98	0.96	ED*4X48L**	*9MPV125	1.00	0.92	EHD4X48A**	*9MPV100	1.01	1.01
ED*4X42F**	MV12F19**B*	0.98	0.89	ED*4X48L**	*9MVX100	1.00	0.92	EHD4X48A**	*9MPV125	1.00	0.92
ED*4X42F**		1.00	1.00	ED*4X48L**	MV20L24**B*	1.00	0.90	EHD4X48A**	*9MVX060	1.00	0.98
ED*4X42J**	*8MPV100	0.99	0.93	ED*4X48L**		1.00	0.98	EHD4X48A**	*9MVX080	1.00	0.94
ED*4X42J**	*8MPV125	0.99	0.93	EHD4X42A**	*8MPV075	0.98	0.96	EHD4X48A**	*9MVX100	1.00	0.92
ED*4X42J**	*9MVX080	0.98	0.93	EHD4X42A**	*8MPV100	0.99	0.93	EHD4X48A**	MV12F19**B*	1.00	0.90
ED*4X42J**	MV16J22**B*	0.99	0.89	EHD4X42A**	*8MPV125	0.99	0.93	EHD4X48A**	MV16J22**B*	1.00	0.90
ED*4X42L**	*9MPV125	0.98	0.92	EHD4X42A**	*8MPV125	1.00	0.92	EHD4X48A**	MV20L24**B*	1.00	0.90
ED*4X42L**	MV20L24**B*	0.99	0.89	EHD4X42A**	*9MPV075	0.98	0.98	EHD4X48A**		1.00	0.98
ED*4X42L**		1.00	1.00	EHD4X42A**	*9MPV100	0.99	0.93	EMA4X48D**		1.00	1.00
ED*4X48F**	*8MPV075	1.00	0.98	EHD4X42A**	*9MPV125	0.98	0.92	FEM4X42****		1.00	0.94
ED*4X48F**	*9MPV075	0.99	0.97	EHD4X42A**	*9MVX060	0.98	0.96	FEM4X48****		1.00	0.92
ED*4X48F**	*9MVX060	0.99	0.97	EHD4X42A**	*9MVX080	0.98	0.93	FS(M,U)4X42***		1.00	1.00

> Indicates Tested Indoor Model

- continued on next page -

COOLING Multiplying Factors for other Indoor Combinations (continued)

Indoor Model	Furnace Model	Capac. (MBh)	Power (AMPS)	Indoor Model	Furnace Model	Capac. (MBh)	Power (AMPS)	Indoor Model	Furnace Model	Capac. (MBh)	Power (AMPS)
ED*4X48F**	MV12F19**B*	1.00	0.90	EHD4X42A**	*9MVX100	0.98	0.89	FS(M,U)4X48***		1.00	0.98
ED*4X48F**		1.00	0.98	EHD4X42A**	MV12F19**B*	0.98	0.89	FSM4X36****		1.00	1.00
ED*4X48J**	*8MPV100	1.01	0.95	EHD4X42A**	MV16J22**B*	0.99	0.89	FVM4X48****		1.00	0.90
ED*4X48J**	*8MPV125	1.00	0.92	EHD4X42A**	MV20L24**B*	1.00	0.90	FVM4X60****		1.00	0.90
ED*4X48J**	*9MPV100	1.01	1.01	EHD4X42A**		1.00	1.00				
(C,H,T)4A348											
>ED*4X48J**		1.00	1.00	ED*4X60J**		1.00	0.98	EHD4X60A**	*9MPV100	1.01	0.95
ED*4X48F**		0.98	0.98	ED*4X60L**	*9MPV125	1.01	0.95	EHD4X60A**	*9MPV125	1.01	0.95
ED*4X48J**	*8MPV100	0.98	0.94	ED*4X60L**	*9MVX100	1.00	0.94	EHD4X60A**	*9MVX080	1.01	0.95
ED*4X48J**	*8MPV125	0.98	0.92	ED*4X60L**	MV20L24**B*	1.01	0.91	EHD4X60A**	*9MVX100	1.00	0.94
ED*4X48J**	*9MPV100	0.98	0.96	ED*4X60L**		1.01	0.99	EHD4X60A**	MV16J22**B*	1.01	0.91
ED*4X48J**	*9MVX080	0.99	0.97	EHD4X48A**	*8MPV100	1.00	0.96	EHD4X60A**	MV20L24**B*	1.01	0.91
ED*4X48J**	MV16J22**B*	0.98	0.90	EHD4X48A**	*8MPV125	1.00	0.94	EHD4X60A**		1.01	0.99
ED*4X48L**	*9MPV125	0.99	0.95	EHD4X48A**	*9MPV100	0.99	0.97	EMA4X48D**		0.98	0.98
ED*4X48L**	*9MVX100	0.98	0.94	EHD4X48A**	*9MPV125	0.99	0.95	FEM4X48****		1.01	0.95
ED*4X48L**	MV20L24**B*	0.99	0.91	EHD4X48A**	*9MVX080	0.99	0.97	FEM4X60****		1.03	0.95
ED*4X48L**		1.00	1.00	EHD4X48A**	*9MVX100	0.98	0.94	FS(M,U)4X48***		0.99	0.97
ED*4X60J**	*8MPV100	1.00	0.94	EHD4X48A**	MV16J22**B*	1.00	0.92	FS(M,U)4X60***		1.01	0.99
ED*4X60J**	*8MPV125	1.00	0.92	EHD4X48A**	MV20L24**B*	1.00	0.92	FVM4X48****		1.00	0.92
ED*4X60J**	*9MPV100	1.00	0.94	EHD4X48A**		1.00	1.00	FVM4X60****		1.01	0.91
ED*4X60J**	*9MVX080	1.01	0.95	EHD4X60A**	*8MPV100	1.01	0.95				
ED*4X60J**	MV16J22**B*	1.00	0.90	EHD4X60A**	*8MPV125	1.01	0.93				
(C,H,T)4A360											
>ED*4X60L**		1.00	1.00	ED*4X60L**	MV20L24**B*	0.99	0.97	EHD4X60A**		1.00	1.00
ED*4X60J**	MV16J22**B*	0.99	0.97	EHD4X60A**	MV16J22**B*	1.00	0.96	FEM4X60****		1.00	0.98
ED*4X60J**		1.00	1.00	EHD4X60A**	MV20L24**B*	0.99	0.97	FVM4X60****		1.00	0.96

> Indicates Tested Indoor Model

NOTE: This illustration is for reference only. Your unit may differ in appearance or may not include all components shown. Please refer to Parts List for exact parts listing.

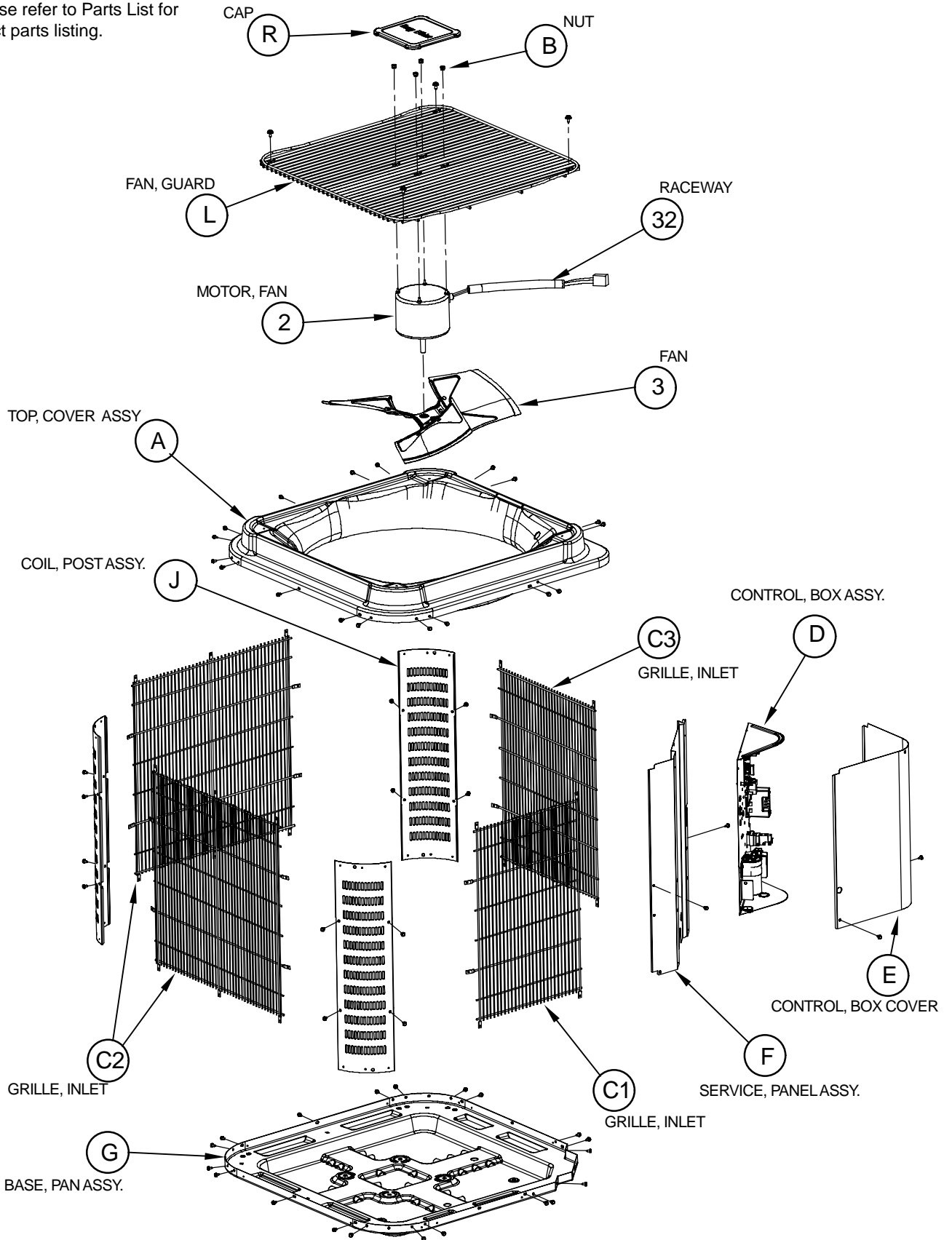

H4A3**GKD100
cabinet

NOTE: This illustration is for reference only. Your unit may differ in appearance or may not include all components shown. Please refer to Parts List for exact parts listing.

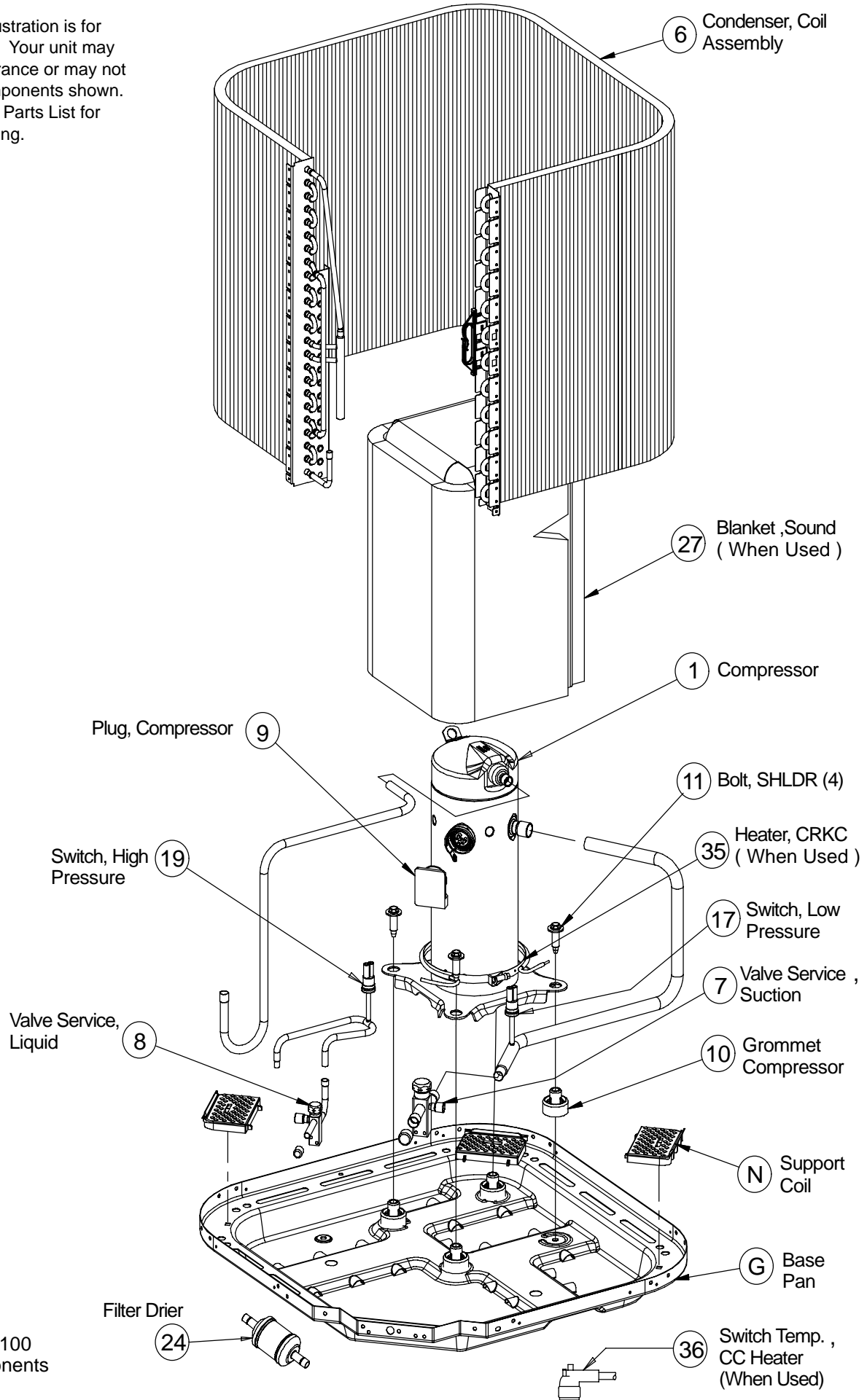

H4A3**GKD100
refrig components

NOTE: This illustration is for reference only. Your unit may differ in appearance or may not include all components shown. Please refer to Parts List for exact parts listing.

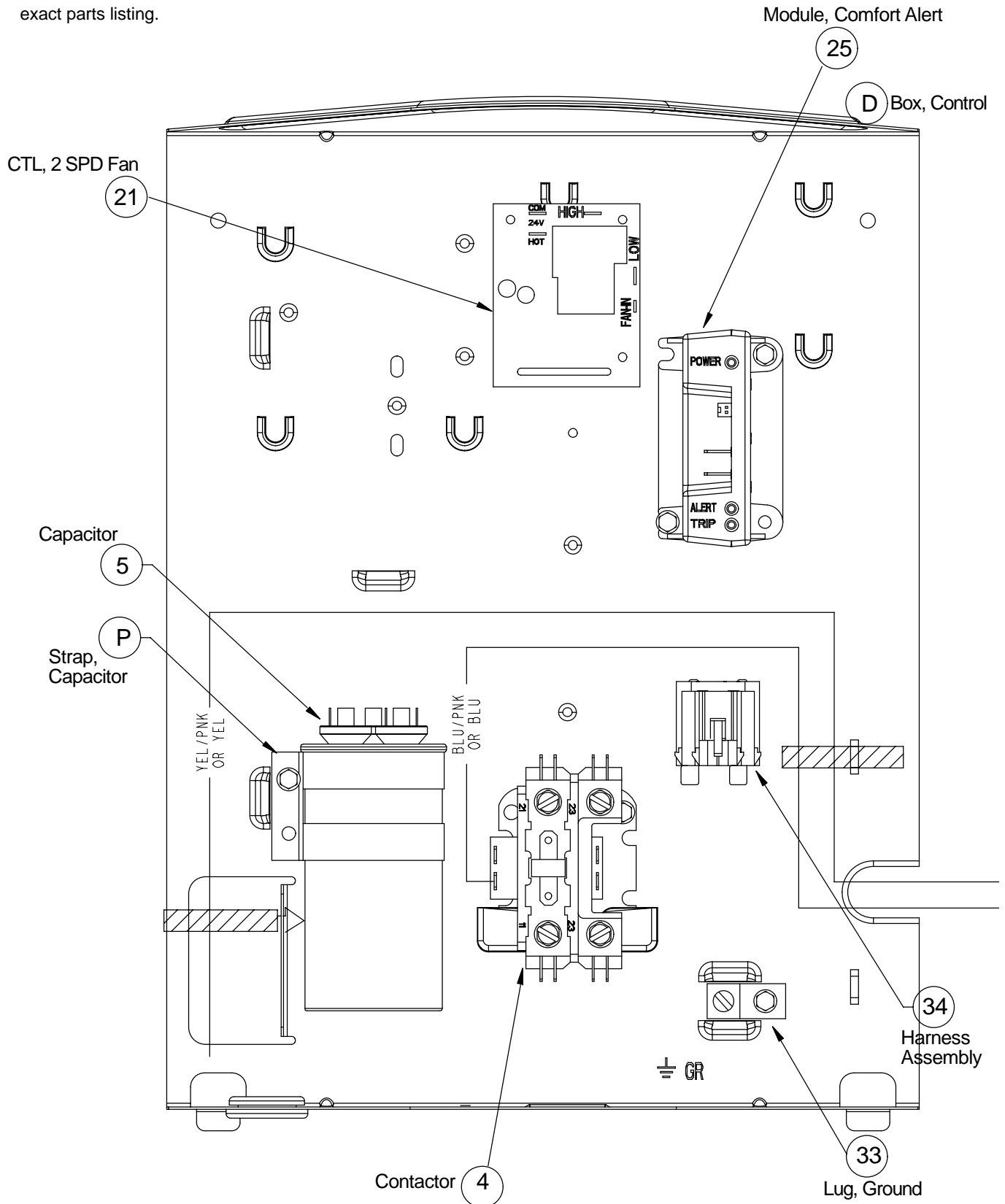

H4A3**GKD100 control box

C4A3 PARTS LIST									
KEY NO.	DESCRIPTION	PART NO.	C4A318GKD100	C4A324GKD100	C4A330GKD100	C4A336GKD100	C4A342GKD100	C4A348GKD100	C4A360GKD100
01	COMPRESSOR	ZP16K5EPFV130	1	-	-	-	-	-	-
01		ZP20K5EPFV130	-	1	-	-	-	-	-
01		ZP24K5EPFV130	-	-	1	-	-	-	-
01		ZP31K5EPFV130	-	-	-	1	-	-	-
01		ZP36K5EPFV130	-	-	-	-	1	-	-
01		ZP39K5EPFV130	-	-	-	-	-	1	-
01		ZP51K5EPFV130	-	-	-	-	-	-	1
02	MOTOR CONDENSER FAN	1177856	1	-	-	-	-	-	-
02		1177857	-	1	1	-	-	-	-
02		1177911	-	-	-	1	1	-	-
02		1177912	-	-	-	-	-	1	1
03	FAN BLADE	1172027	1	-	-	-	-	-	-
03		1174760	-	1	1	-	-	-	-
03		1177890	-	-	-	1	1	-	-
03		1177891	-	-	-	-	-	1	1
04	CONTACTOR 30 AMP 1 POLE	1172472	1	1	1	1	1	1	-
04	40AMP 2 POLE	1172786	-	-	-	-	-	-	1
05	CAPACITOR 370V 30+5 MFD	1172109	1	-	-	-	-	-	-
05	CAPACITOR 370V 45+5 MFD	1172124	-	-	-	1	1	1	-
05	35+5 MFD 370V	1172110	-	1	-	-	-	-	-
05	40+5 MFD 370V	1172147	-	-	1	-	-	-	-
05	70+5 MFD 370V	1172163	-	-	-	-	-	-	1
06	CONDENSER COIL KIT	1177842	1	-	-	-	-	-	-
06		1177843	-	1	-	-	-	-	-
06		1177846	-	-	1	-	-	-	-
06		1178053	-	-	-	1	-	-	-
06		1172719	-	-	-	-	1	-	-
06		1178055	-	-	-	-	-	1	-
06		1178054	-	-	-	-	-	-	1
07	SERVICE VALVE SUCTION	1172726	1	1	1	-	-	-	-
07		1172727	-	-	-	1	1	1	1
08	SERVICE VALVE LIQUID	1172728	1	1	1	1	1	1	1
09	PLUG COMPRESSOR	1173905	1	1	1	-	-	-	-
09		1174686	-	-	-	1	-	-	1
09		1173963	-	-	-	-	1	-	-
09		1173921	-	-	-	-	-	1	-
10	GROMMET COMPRESSOR	1171270	4	4	4	4	4	4	4
11	BOLT COMPRESSOR MOUNTING	1173630	4	4	4	4	4	4	4

- continued on next page -

C4A3 PARTS LIST									
KEY NO.	DESCRIPTION	PART NO.	C4A318GKD100	C4A324GKD100	C4A330GKD100	C4A336GKD100	C4A342GKD100	C4A348GKD100	C4A360GKD100
17	SWITCH LOW PRESSURE	1177095	1	1	1	1	1	1	1
19	SWITCH HIGH PRESSURE	1174684	1	1	1	1	1	1	1
20	DISTRUBITOR	1172021	-	-	-	-	-	1	-
20		1172022	-	-	-	-	-	-	1
21	CTRL 2 SPEED FAN	1088977	1	1	1	1	1	1	1
25	MODULE DIGN COMFORTALERT	1177402	1	1	1	1	1	1	1
27	SOUND BLANKET	1177810	1	1	1	1	-	-	-
27		1172014	-	-	-	-	1	1	1
32	RACEWAY	1177839	1	1	1	-	-	-	-
32		1175919	-	-	-	1	1	1	1
33	LUG GROUND	1172300	1	1	1	1	1	1	1
34	HARNESS ASSY PLUG & PLAY	1173909	1	1	1	1	1	1	-
34		1173951	-	-	-	-	-	-	1
)	FILTER DRIER	1174195	1	1	1	1	1	1	-
)		1174196	-	-	-	-	-	-	1
)	FILTER DRIER	1174194	1	1	1	1	-	-	-
)		1174193	-	-	-	-	1	1	1
)	HARNESS ASSY COMF ALERT AC	1177426	1	1	1	1	1	1	1
)	CAP SERVICE KIT 11/16-20	1175650	1	1	1	1	1	1	1
)	CAP SERVICE KIT 15/16-20	1175651	1	1	1	1	-	-	-
)		1175652	-	-	-	-	1	1	1
)	GROMMET	1171737	1	1	1	1	1	1	1
A	PANEL TOP	1177854	1	1	1	-	-	-	-
A		1177888	-	-	-	1	1	1	1
B	NUT HEX	1172217	4	4	4	4	4	4	4
C1	GRILLE INLET	1177864	1	1	-	-	-	-	-
C1		1177865	-	-	1	-	-	-	-
C1		1177895	-	-	-	1	-	-	-
C1		1176678	-	-	-	-	1	-	-
C1		1176359	-	-	-	-	-	1	-
C1		1177404	-	-	-	-	-	-	1
C2	GRILLE INLET	1177870	2	2	-	-	-	-	-
C2		1177871	-	-	2	-	-	-	-
C2		1177898	-	-	-	2	-	-	-
C2		1178056	-	-	-	-	2	-	-
C2		1177977	-	-	-	-	-	2	-
C2		1177968	-	-	-	-	-	-	2

- continued on next page -

C4A3 PARTS LIST									
KEY NO.	DESCRIPTION	PART NO.	C4A318GKD100	C4A324GKD100	C4A330GKD100	C4A336GKD100	C4A342GKD100	C4A348GKD100	C4A360GKD100
C3	GRILLE INLET	1177876	1	1	-	-	-	-	-
C3		1177877	-	-	1	-	-	-	-
C3		1177903	-	-	-	1	-	-	-
C3		1178059	-	-	-	-	1	-	-
C3		1177980	-	-	-	-	-	1	-
C3		1177971	-	-	-	-	-	-	1
D	BOX CONTROL	1172753	1	1	1	1	1	1	1
E	KIT CONTROL BOX COVER ASSY	1177885	1	-	-	-	-	-	-
E		1177886	-	1	-	-	-	-	-
E		1177887	-	-	1	-	-	-	-
E		1178049	-	-	-	1	-	-	-
E		1178050	-	-	-	-	1	-	-
E		1178051	-	-	-	-	-	1	-
E		1178052	-	-	-	-	-	-	1
F	PANEL SERVICE	1172755	1	1	-	1	-	-	-
F		1174066	-	-	1	-	-	-	1
F		1174071	-	-	-	-	1	-	-
F		1174080	-	-	-	-	-	1	-
G	PAN BASE	1177648	1	1	1	-	-	-	-
G		1176406	-	-	-	1	1	1	1
J	CORNER POST ASSY	1177861	1	1	-	1	-	-	-
J		1175928	-	-	1	-	-	-	1
J		1175929	-	-	-	-	1	-	-
J		1175930	-	-	-	-	-	1	-
L	GUARD FAN	1177858	1	1	1	-	-	-	-
L		1177892	-	-	-	1	1	1	1
N	SUPPORT COIL	1174068	3	3	3	5	5	5	5
P	STRAP CAPACITOR	1172734	1	1	1	1	1	1	-
P		1172735	-	-	-	-	-	-	1
R	MOTOR CAP ASSY	1173970	1	1	1	1	1	1	1
)	PAINT TOUCH UP 1PT	1174415	1	1	1	1	1	1	1
)	SCREW HEX HD 10AB 3/8	1176782	44	44	44	44	44	44	44
)	Manual, Installation	42101510201	1	1	1	1	1	1	1
)	Manual, Owners	42102500000	1	1	1	1	1	1	1
)	Warranty	40106430001	1	1	1	1	1	1	1

H4A3 PARTS LIST									
KEY NO.	DESCRIPTION	PART NO.	H4A318GKD100	H4A324GKD100	H4A330GKD100	H4A336GKD100	H4A342GKD100	H4A348GKD100	H4A360GKD100
01	COMPRESSOR	ZP16K5EPFV130	1	-	-	-	-	-	-
01		ZP20K5EPFV130	-	1	-	-	-	-	-
01		ZP24K5EPFV130	-	-	1	-	-	-	-
01		ZP31K5EPFV130	-	-	-	1	-	-	-
01		ZP36K5EPFV130	-	-	-	-	1	-	-
01		ZP39K5EPFV130	-	-	-	-	-	1	-
01		ZP51K5EPFV130	-	-	-	-	-	-	1
02	MOTOR CONDENSER FAN	1177856	1	-	-	-	-	-	-
02		1177857	-	1	1	-	-	-	-
02		1177911	-	-	-	1	1	-	-
02		1177912	-	-	-	-	-	1	1
03	FAN BLADE	1172027	1	-	-	-	-	-	-
03		1174760	-	1	1	-	-	-	-
03		1177890	-	-	-	1	1	-	-
03		1177891	-	-	-	-	-	1	1
04	CONTACTOR 30 AMP 1 POLE	1172472	1	1	1	1	1	1	-
04	40AMP 2 POLE	1172786	-	-	-	-	-	-	1
05	CAPACITOR 370V 30+5 MFD	1172109	1	-	-	-	-	-	-
05	CAPACITOR 370V 45+5 MFD	1172124	-	-	-	1	1	1	-
05	35+5 MFD 370V	1172110	-	1	-	-	-	-	-
05	40+5 MFD 370V	1172147	-	-	1	-	-	-	-
05	70+5 MFD 370V	1172163	-	-	-	-	-	-	1
06	CONDENSER COIL KIT	1177842	1	-	-	-	-	-	-
06		1177843	-	1	-	-	-	-	-
06		1177846	-	-	1	-	-	-	-
06	CONDENSER COIL KIT	1178053	-	-	-	1	-	-	-
06		1172719	-	-	-	-	1	-	-
06		1178055	-	-	-	-	-	1	-
06		1178054	-	-	-	-	-	-	1
07	SERVICE VALVE SUCTION	1172726	1	1	1	-	-	-	-
07		1172727	-	-	-	1	1	1	1
08	SERVICE VALVE LIQUID	1172728	1	1	1	1	1	1	1
09	PLUG COMPRESSOR	1173905	1	1	1	-	-	-	-
09	PLUG COMPRESSOR	1174686	-	-	-	1	-	-	1
09		1173963	-	-	-	-	1	-	-
09		1173921	-	-	-	-	-	1	-
10	GROMMET COMPRESSOR	1171270	4	4	4	4	4	4	4
11	BOLT COMPRESSOR MOUNTING	1173630	4	4	4	4	4	4	4

- continued on next page -

H4A3 PARTS LIST									
KEY NO.	DESCRIPTION	PART NO.	H4A318GKD100	H4A324GKD100	H4A330GKD100	H4A336GKD100	H4A342GKD100	H4A348GKD100	H4A360GKD100
17	SWITCH LOW PRESSURE	1177095	1	1	1	1	1	1	1
19	SWITCH HIGH PRESSURE	1174684	1	1	1	1	1	1	1
20	DISTRUBITOR	1172021	-	-	-	-	-	1	-
20		1172022	-	-	-	-	-	-	1
21	CTRL 2 SPEED FAN	1088977	1	1	1	1	1	1	1
25	MODULE DIGN COMFORTALERT	1177402	1	1	1	1	1	1	1
27	SOUND BLANKET	1177810	1	1	1	1	-	-	-
27		1172014	-	-	-	-	1	1	1
32	RACEWAY	1177839	1	1	1	-	-	-	-
32		1175919	-	-	-	1	1	1	1
33	LUG GROUND	1172300	1	1	1	1	1	1	1
34	HARNESS ASSY PLUG & PLAY	1173909	1	1	1	1	1	1	-
34		1173951	-	-	-	-	-	-	1
)	FILTER DRIER	1174195	1	1	1	1	1	1	-
)		1174196	-	-	-	-	-	-	1
)	FILTER DRIER	1174194	1	1	1	1	-	-	-
)		1174193	-	-	-	-	1	1	1
)	HARNESS ASSY COMF ALERT AC	1177426	1	1	1	1	1	1	1
)	CAP SERVICE KIT 11/16-20	1175650	1	1	1	1	1	1	1
)	CAP SERVICE KIT 15/16-20	1175651	1	1	1	1	-	-	-
)		1175652	-	-	-	-	1	1	1
)	GROMMET	1171737	1	1	1	1	1	1	1
A	PANEL TOP	1177855	1	1	1	-	-	-	-
A		1177889	-	-	-	1	1	1	1
B	NUT HEX	1172217	4	4	4	4	4	4	4
C1	GRILLE INLET	1177866	1	1	-	-	-	-	-
C1		1177867	-	-	1	-	-	-	-
C1		1177896	-	-	-	1	-	-	-
C1		1176706	-	-	-	-	1	-	-
C1		1176433	-	-	-	-	-	1	-
C1		1177419	-	-	-	-	-	-	1
C2	GRILLE INLET	1177872	2	2	-	-	-	-	-
C2		1177873	-	-	2	-	-	-	-
C2		1177915	-	-	-	2	-	-	-
C2		1178057	-	-	-	-	2	-	-
C2		1177978	-	-	-	-	-	2	-
C2		1177969	-	-	-	-	-	-	2

- continued on next page -

H4A3 PARTS LIST									
KEY NO.	DESCRIPTION	PART NO.	H4A318GKD100	H4A324GKD100	H4A330GKD100	H4A336GKD100	H4A342GKD100	H4A348GKD100	H4A360GKD100
C3	GRILLE INLET	1177878	1	1	-	-	-	-	-
C3		1177879	-	-	1	-	-	-	-
C3		1177905	-	-	-	1	-	-	-
C3		1178060	-	-	-	-	1	-	-
C3		1177981	-	-	-	-	-	1	-
C3		1177972	-	-	-	-	-	-	1
D	BOX CONTROL	1172753	1	1	1	-	-	-	-
E	KIT CONTROL BOX COVER ASSY	1177885	1	-	-	-	-	-	-
E		1177886	-	1	-	-	-	-	-
E		1177887	-	-	1	-	-	-	-
E		1178049	-	-	-	1	-	-	-
E		1178050	-	-	-	-	1	-	-
E		1178051	-	-	-	-	-	1	-
E		1178052	-	-	-	-	-	-	1
F	PANEL SERVICE	1172755	1	1	-	-	-	-	-
F		1174066	-	-	1	-	-	-	1
F		1174080	-	-	-	-	-	1	-
G	PAN BASE	1177648	1	1	1	-	-	-	-
J	CORNER POST ASSY	1177862	1	1	-	1	-	-	-
J		1175927	-	-	1	-	-	-	1
J		1175810	-	-	-	-	1	-	-
J		1175811	-	-	-	-	-	1	-
L	GUARD FAN	1177859	1	1	1	-	-	-	-
L		1177893	-	-	-	1	1	1	1
N	SUPPORT COIL	1174068	3	3	3	5	5	5	5
P	STRAP CAPACITOR	1172734	1	1	1	1	1	1	-
P		1172735	-	-	-	-	-	-	1
R	MOTOR CAP ASSY	1174729	1	1	1	1	1	1	1
)	PAINT TOUCH UP 1PT	1174415	1	1	1	1	1	1	1
)	SCREW HEX HD 10AB 3/8	1176782	44	44	44	44	44	44	44
)	Manual, Installation	42101510201	1	1	1	1	1	1	1
)	Manual, Owners	42102500000	1	1	1	1	1	1	1
)	Warranty	40106430001	1	1	1	1	1	1	1

T4A3 PARTS LIST									
KEY NO.	DESCRIPTION	PART NO.	T4A318GKD100	T4A324GKD100	T4A330GKD100	T4A336GKD100	T4A342GKD100	T4A348GKD100	T4A360GKD100
01	COMPRESSOR	ZP16K5EPFV130	1	-	-	-	-	-	-
01		ZP20K5EPFV130	-	1	-	-	-	-	-
01		ZP24K5EPFV130	-	-	1	-	-	-	-
01		ZP31K5EPFV130	-	-	-	1	-	-	-
01		ZP36K5EPFV130	-	-	-	-	1	-	-
01		ZP39K5EPFV130	-	-	-	-	-	1	-
01		ZP51K5EPFV130	-	-	-	-	-	-	1
02	MOTOR CONDENSER FAN	1177856	1	-	-	-	-	-	-
02		1177857	-	1	1	-	-	-	-
02		1177911	-	-	-	1	1	-	-
02		1177912	-	-	-	-	-	1	1
03	FAN BLADE	1172027	1	-	-	-	-	-	-
03		1174760	-	1	1	-	-	-	-
03	FAN BLADE	1177890	-	-	-	1	1	-	-
03		1177891	-	-	-	-	-	1	1
04	CONTACTOR 30 AMP 1 POLE	1172472	1	1	1	1	1	1	-
04	40AMP 2 POLE	1172786	-	-	-	-	-	-	1
05	CAPACITOR 370V 30+5 MFD	1172109	1	-	-	-	-	-	-
05	35+5 MFD 370V	1172110	-	1	-	-	-	-	-
05	40+5 MFD 370V	1172147	-	-	1	-	-	-	-
05	CAPACITOR 370V 45+5 MFD	1172124	-	-	-	1	1	1	-
05	70+5 MFD 370V	1172163	-	-	-	-	-	-	1
06	CONDENSER COIL KIT	1177842	1	-	-	-	-	-	-
06		1177843	-	1	-	-	-	-	-
06		1177846	-	-	1	-	-	-	-
06		1178053	-	-	-	1	-	-	-
06		1172719	-	-	-	-	1	-	-
06		1178055	-	-	-	-	-	1	-
06		1178054	-	-	-	-	-	-	1
07	SERVICE VALVE SUCTION	1172726	1	1	1	-	-	-	-
07		1172727	-	-	-	1	1	1	1
08	SERVICE VALVE LIQUID	1172728	1	1	1	1	1	1	1
09	PLUG COMPRESSOR	1173905	1	1	1	-	-	-	-
09		1174686	-	-	-	1	-	-	1
09		1173963	-	-	-	-	1	-	-
09		1173921	-	-	-	-	-	1	-
10	GROMMET COMPRESSOR	1171270	4	4	4	4	4	4	4
11	BOLT COMPRESSOR MOUNTING	1173630	4	4	4	4	4	4	4

- continued on next page -

T4A3 PARTS LIST									
KEY NO.	DESCRIPTION	PART NO.	T4A318GKD100	T4A324GKD100	T4A330GKD100	T4A336GKD100	T4A342GKD100	T4A348GKD100	T4A360GKD100
17	SWITCH LOW PRESSURE	1177095	1	1	1	1	1	1	1
19	SWITCH HIGH PRESSURE	1174684	1	1	1	1	1	1	1
20	DISTRUBITOR	1172021	-	-	-	-	-	1	-
20		1172022	-	-	-	-	-	-	1
21	CTRL 2 SPEED FAN	1088977	1	1	1	1	1	1	1
25	MODULE DIGN COMFORTALERT	1177402	1	1	1	1	1	1	1
27	SOUND BLANKET	1177810	1	1	1	1	-	-	-
27		1172014	-	-	-	-	1	1	1
32	RACEWAY	1177839	1	1	1	-	-	-	-
32	RACEWAY	1175919	-	-	-	1	1	1	1
33	LUG GROUND	1172300	1	1	1	1	1	1	1
34	HARNESS ASSY PLUG & PLAY	1173909	1	1	1	1	1	1	-
34		1173951	-	-	-	-	-	-	1
)	FILTER DRIER	1174195	1	1	1	1	1	1	-
		1174196	-	-	-	-	-	-	1
)	FILTER DRIER	1174194	1	1	1	1	-	-	-
)		1174193	-	-	-	-	1	1	1
)	HARNESS ASSY COMF ALERT AC	1177426	1	1	1	1	1	1	1
)	CAP SERVICE KIT 11/16-20	1175650	1	1	1	1	1	1	1
)	CAP SERVICE KIT 15/16-20	1175651	1	1	1	1	-	-	-
)		1175652	-	-	-	-	1	1	1
)	GROMMET	1171737	1	1	1	1	1	1	1
A	PANEL TOP	1177854	-	-	-	-	-	-	-
A		1177855	1	1	1	-	-	-	-
A		1177888	-	-	-	1	1	1	1
A		1177889	-	-	-	-	-	-	-
B	NUT HEX	1172217	4	4	4	4	4	4	4
C1	GRILLE INLET	1177868	1	1	-	-	-	-	-
C1		1177869	-	-	1	-	-	-	-
C1	GRILLE INLET	1177897	-	-	-	1	-	-	-
C1		1176722	-	-	-	-	1	-	-
C1		1176437	-	-	-	-	-	1	-
C1		1177422	-	-	-	-	-	-	1
C2	GRILLE INLET	1177874	2	2	-	-	-	-	-
C2		1177875	-	-	2	-	-	-	-
C2	GRILLE INLET	1177901	-	-	-	2	-	-	-
C2		1178058	-	-	-	-	2	-	-

- continued on next page -

T4A3 PARTS LIST									
KEY NO.	DESCRIPTION	PART NO.	T4A318GKD100	T4A324GKD100	T4A330GKD100	T4A336GKD100	T4A342GKD100	T4A348GKD100	T4A360GKD100
C2		1177979	-	-	-	-	-	2	-
C2		1177970	-	-	-	-	-	-	2
C3	GRILLE INLET	1177880	1	1	-	-	-	-	-
C3		1177881	-	-	1	-	-	-	-
C3	GRILLE INLET	1177907	-	-	-	1	-	-	-
C3		1178061	-	-	-	-	1	-	-
C3		1177982	-	-	-	-	-	1	-
C3		1177973	-	-	-	-	-	-	1
D	BOX CONTROL	1172753	1	1	1	1	1	1	1
E	KIT CONTROL BOX COVER ASSY	1177885	1	-	-	-	-	-	-
E		1177886	-	1	-	-	-	-	-
E		1177887	-	-	1	-	-	-	-
E		1178049	-	-	-	1	-	-	-
E		1178050	-	-	-	-	1	-	-
E		1178051	-	-	-	-	-	1	-
E		1178052	-	-	-	-	-	-	1
F	PANEL SERVICE	1172755	1	1	-	1	-	-	-
F		1174066	-	-	1	-	-	-	1
F		1174071	-	-	-	-	1	-	-
F		1174080	-	-	-	-	-	1	-
G	PAN BASE	1177648	1	1	1	-	-	-	-
G	PAN BASE	1176406	-	-	-	1	1	1	1
J	CORNER POST ASSY	1175927	-	-	1	-	-	-	-
J		1177863	1	1	-	1	-	-	-
J		1175935	-	-	-	-	1	-	-
J		1175936	-	-	-	-	-	1	-
J		1175934	-	-	-	-	-	-	1
L	GUARD FAN	1177860	1	1	1	-	-	-	-
L		1177894	-	-	-	1	1	1	1
N	SUPPORT COIL	1174068	3	3	3	5	5	5	5
P	STRAP CAPACITOR	1172734	1	1	1	1	1	1	-
P		1172735	-	-	-	-	-	-	1
R	MOTOR CAP ASSY	1174733	1	1	1	1	1	1	1
)	PAINT TOUCH UP 1PT	1174415	1	1	1	1	1	1	1
)	SCREW HEX HD 10AB 3/8	1176782	44	44	44	44	44	44	44
)	Manual, Installation	42101510201	1	1	1	1	1	1	1
)	Manual, Owners	42102500000	1	1	1	1	1	1	1
)	Warranty	40106430001	1	1	1	1	1	1	1

OUTDOOR UNIT MODEL NUMBER IDENTIFICATION GUIDE (single phase)											
Digit Position:	1	2	3	4	5, 6	7	8	9	10	11	12
Example Part Number:	H	4	A	3	18	G	K	D	1	0	0
Product Family		REFRIGERANT		TYPE		NOMINAL EFFICIENCY		NOMINAL CAPACITY		FEATURES	
2 = R-22		4 = R-410A		A = Air Conditioner		H = Heat Pump		3 = 13 SEER		4 = 14 SEER	
5 = 15 SEER		6 = 16 SEER		7 = 17 SEER		8 = 18 SEER		18 = 18,000 BTUH = 1½ tons		24 = 24,000 BTUH = 2 tons	
30 = 30,000 BTUH = 2½ tons		36 = 36,000 BTUH = 3 tons		42 = 42,000 BTUH = 3½ tons		48 = 48,000 BTUH = 4 tons		60 = 60,000 BTUH = 5 tons		A = Standard Grille	
G = Coil Guard Grille		C = Coastal		K = 208/230-1-60		Sales Code		Engineering Revision		Extra Digit	
Extra Digit		Extra Digit		Extra Digit		Extra Digit		Extra Digit		Extra Digit	

ACCESSORIES PART NUMBER IDENTIFICATION GUIDE									
Digit Position:	1	2	3	4	5	6, 7	8, 9	10, 11	
Example Part Number:	N	A	S	A	0	01	01	CH	
N = Non-Branded		BRANDING		A = Accessory		PRODUCT GROUP		S = Split System (AC & HP)	
A = Original		B = 2nd Generation		0 = Generic or Not Applicable		2 = R-22		4 = R-410A	
Product Identifier Number		Package Quantity		Type of Kit (Example: CH = Crankcase Heater)		REFRIGERANT			