



# FEM4P, FSM4P, FSU4P Product Specifications

## FAN COILS

### ALL MODELS

- 1½ thru 4 tons (with FEM4P 5 Ton available)
- Available for Environmentally Sound R-410A systems
- Factory installed Piston metering device with Teflon ring
- Copper tube / aluminum fin coil
- Sweat connections
- Primary and secondary drain fittings with brass inserts
- Multiple electrical entry locations
- Time delay relay (TDR)
- Field installed heater packages from 5 kW – 30 kW available separately
- HUD approved for manufactured housing
- 208/230–1–60 supply voltage
- Units tested and certified by manufacturer to achieve a 2% or less leakage rate at 1.0 inch water column
- 1 inch thick insulation with R value of 4.2
- Filter available as accessory

### FEM4P

- X-13 ECM, 5-speed motor
- Multiposition installation – upflow or horizontal left standard, horizontal right with minor modification (field convertible to downflow with available accessory kit)
- Low voltage circuit protective fuse (3amp) inline on wire harness
- No Heat (Plug) Kit factory installed

### FSM4P

- PSC 2-speed motor
- Multiposition installation – upflow or horizontal left standard, horizontal right with minor modification (field convertible to downflow with available accessory kit)
- Printed circuit board (PCB) with low voltage circuit protective fuse (5 amp)
- No Heat (Plug) Kit factory installed

### FSU4P

- PSC 2-speed motor
- Upflow installation (field convertible to downflow with available accessory kits)
- Printed circuit board (PCB) with low voltage circuit protective fuse (5 amp)



Available Styles	FEM4P	FSM4P	FSU4P
Upflow	✓	✓	✓
Horizontal	✓	✓	-
Downflow	kit	kit	kit
Motor	X-13	PSC	



Use of the AHRI Certified TM Mark indicates a manufacturer's participation in the program. For verification of certification for individual products, go to [www.ahridirectory.org](http://www.ahridirectory.org).

Model Number	Tons	Nom. CFM (L/s)	Dimensions H x W x D in. (mm)	Filter Size in. (mm)	Ship Wt lbs. (kg)
FEM4P1800A	1½	600 (283)	42 <sup>11</sup> / <sub>16</sub> x 14 <sup>5</sup> / <sub>16</sub> x 22 <sup>1</sup> / <sub>16</sub> (1084 x 364 x 560)	13 x 21½ (330 x 546)	112 (51)
FSM4P1800A FSU4P1800A			47 <sup>5</sup> / <sub>8</sub> x 17 <sup>5</sup> / <sub>8</sub> x 22 <sup>1</sup> / <sub>16</sub> (1210 x 448 x 560)	16 <sup>3</sup> / <sub>8</sub> x 21½ (416 x 546)	117 (53)
FEM4P2400A			42 <sup>11</sup> / <sub>16</sub> x 14 <sup>5</sup> / <sub>16</sub> x 22 <sup>1</sup> / <sub>16</sub> (1084 x 364 x 560)	13 x 21½ (330 x 546)	112 (51)
FSM4P2400A FSU4P2400A	2	800 (378)	49 <sup>5</sup> / <sub>8</sub> x 17 <sup>5</sup> / <sub>8</sub> x 22 <sup>1</sup> / <sub>16</sub> (1261 x 448 x 560)	16 <sup>3</sup> / <sub>8</sub> x 21½ (416 x 546)	128 (58)
FEM4P3000A			49 <sup>5</sup> / <sub>8</sub> x 17 <sup>5</sup> / <sub>8</sub> x 22 <sup>1</sup> / <sub>16</sub> (1261 x 448 x 560)	16 <sup>3</sup> / <sub>8</sub> x 21½ (416 x 546)	122 (55)
FSM4P3000A FSU4P3000A	2½	1000 (472)	53 <sup>7</sup> / <sub>16</sub> x 21 <sup>1</sup> / <sub>8</sub> x 22 <sup>1</sup> / <sub>16</sub> (1357 x 537 x 560)	19 <sup>7</sup> / <sub>8</sub> x 21½ (505 x 546)	145 (66)
FEM4P3600A			49 <sup>5</sup> / <sub>8</sub> x 17 <sup>5</sup> / <sub>8</sub> x 22 <sup>1</sup> / <sub>16</sub> (1261 x 448 x 560)	16 <sup>3</sup> / <sub>8</sub> x 21½ (416 x 546)	122 (55)
FSM4P3600A FSU4P3600A	3	1200 (566)	53 <sup>7</sup> / <sub>16</sub> x 21 <sup>1</sup> / <sub>8</sub> x 22 <sup>1</sup> / <sub>16</sub> (1357 x 537 x 560)	19 <sup>7</sup> / <sub>8</sub> x 21½ (505 x 546)	148 (67)
FEM4P4200A			49 <sup>5</sup> / <sub>8</sub> x 21 <sup>1</sup> / <sub>8</sub> x 22 <sup>1</sup> / <sub>16</sub> (1261 x 537 x 560)	19 <sup>7</sup> / <sub>8</sub> x 21½ (505 x 546)	157 (71)
FSM4P4200A FSU4P4200A	3½	1400 (661)	49 <sup>5</sup> / <sub>8</sub> x 21 <sup>1</sup> / <sub>8</sub> x 22 <sup>1</sup> / <sub>16</sub> (1261 x 537 x 560)	19 <sup>7</sup> / <sub>8</sub> x 21½ (505 x 546)	156 (71)
FEM4P4800A			49 <sup>5</sup> / <sub>8</sub> x 21 <sup>1</sup> / <sub>8</sub> x 22 <sup>1</sup> / <sub>16</sub> (1261 x 537 x 560)	19 <sup>7</sup> / <sub>8</sub> x 21½ (505 x 546)	157 (71)
FSM4P4800A FSU4P4800A	4	1600 (755)	53 <sup>7</sup> / <sub>16</sub> x 24 <sup>11</sup> / <sub>16</sub> x 22 <sup>1</sup> / <sub>16</sub> (1357 x 627 x 560)	23 <sup>5</sup> / <sub>16</sub> x 21½ (592 x 546)	182 (83)
FEM4P6000A			53 <sup>7</sup> / <sub>16</sub> x 21 <sup>1</sup> / <sub>8</sub> x 22 <sup>1</sup> / <sub>16</sub> (1357 x 537 x 560)	19 <sup>7</sup> / <sub>8</sub> x 21½ (505 x 546)	175 (79)

**FAN COIL MODEL NUMBER IDENTIFICATION GUIDE**

	<b>F</b>	<b>E</b>	<b>M</b>	<b>4</b>	<b>P</b>	<b>1800</b>	<b>A</b>	<b>1</b>
F = Fan Coil								
S = Standard PSC								
E = X-13 ECM		<b>MOTOR TYPE</b>						
U = Upflow								
M = Multiposition		<b>INSTALLATION TYPE</b>						
4 = Environmentally Sound R-410A				<b>REFRIGERANT</b>				
P = Piston Metering Device						<b>METERING DEVICE</b>		
1800 = 18,000 BTUH = 1½ tons								
2400 = 24,000 BTUH = 2 tons								
3000 = 30,000 BTUH = 2½ tons								
3600 = 36,000 BTUH = 3 tons								
4200 = 42,000 BTUH = 3½ tons								
4800 = 48,000 BTUH = 4 tons								
6000 = 60,000 BTUH = 5 tons						<b>NOMINAL CAPACITY</b>		
Sales Code								
Engineering Revision								

**ACCESSORIES PART NUMBER IDENTIFICATION GUIDE**

	<b>EB</b>	<b>AC</b>	<b>01</b>	<b>NCB</b>	<b>A</b>
EB = Evaporator Blower					
AC = Accessory					
01 = Product Identifier Number					
NCB = Non-Combustible Base Kit					
DFK = Down Flow Kit					
PLG = Power Plug (no heat kit)					
SPK = Single Point Wiring Kit					
FKS = Filter Kit Small					
FKM = Filter Kit Medium					
FKL = Filter Kit Large					
FKX = Filter Kit Extra Large					
CTK = Condensate Trap Kit (PVC pipe)					
Sales Code					

**ELECTRIC HEATER MODEL NUMBER IDENTIFICATION GUIDE**

	<b>EHK</b>	<b>05</b>	<b>A</b>	<b>K</b>	<b>N</b>	<b>1</b>
EHK = Electric Heater Kit						
05 = 5 kW						
07 = 7 kW						
09 = 9 kW						
10 = 10 kW						
15 = 15 kW						
18 = 18 kW						
20 = 20 kW						
25 = 25 kW						
30 = 30 kW		<b>NOMINAL HEAT VALUE</b>				
Sales Code						
K = 208 / 230 single-phase						
H = 208 / 230, 3-phase						
KC = 208 / 230, supplied as single phase, field convertible to 3-phase						
HC = 208 / 230 supplied as 3-phase, field convertible to single phase				<b>VOLTAGE (60 Hz)</b>		
Product Identifier						
Engineering Code						

**WARRANTY\***

	No Hassle	Parts Limited Warranty
<b>FEM4P</b>	1 Year	5 year – With timely registration, an additional 5 year.
<b>FSM4P</b>	–	5 year – With timely registration, an additional 5 year.
<b>FSU4P</b>	–	5 year – With timely registration, an additional 5 year.

\* Applies to original purchaser/homeowner, some limitations may apply. See Warranty certificate for complete details.

**CLEARANCES AND UNIT DIMENSIONS – FEM4P**

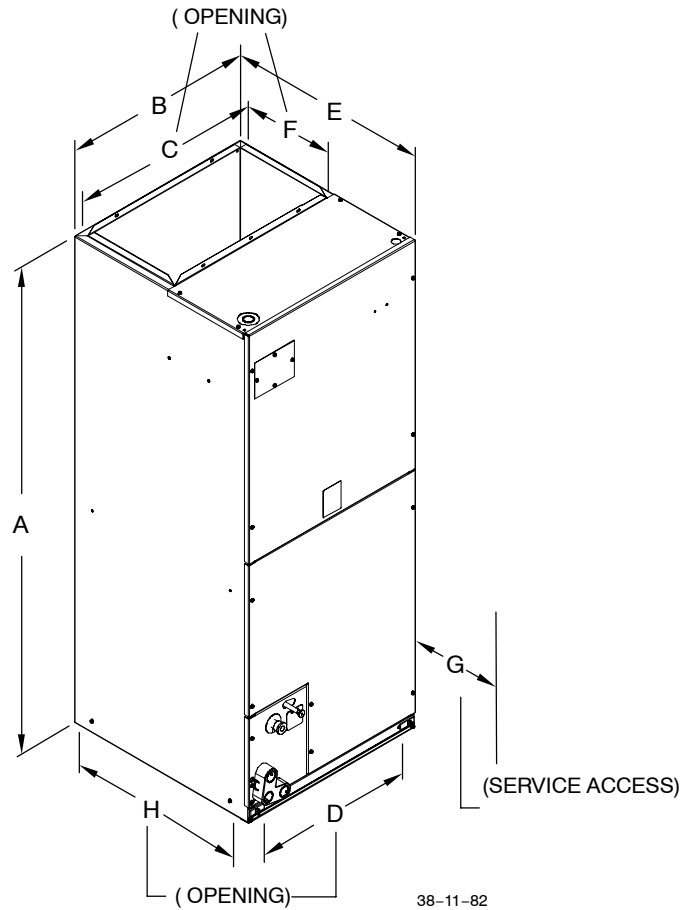

38-11-82

REQUIRED CLEARANCES – ALL MODELS inches (mm)								
No Heaters	All Sides	0						
	From Supply Duct	0						
With Heaters	All Sides	0						
	From First 3 feet of Supply Duct to Combustibles	1 (25)						
	From Supply Duct to Combustibles after 3 feet	0						
FEM4P inches (English)								
Unit Size	A	B	C	D	E	F	G	H
1800	42 <sup>1</sup> / <sub>16</sub>	14 <sup>5</sup> / <sub>16</sub>	12 <sup>7</sup> / <sub>16</sub>	12 <sup>5</sup> / <sub>16</sub>	22 <sup>1</sup> / <sub>16</sub>	11	21	19 <sup>13</sup> / <sub>16</sub>
2400	42 <sup>1</sup> / <sub>16</sub>	14 <sup>5</sup> / <sub>16</sub>	12 <sup>7</sup> / <sub>16</sub>	12 <sup>5</sup> / <sub>16</sub>	22 <sup>1</sup> / <sub>16</sub>	11	21	19 <sup>13</sup> / <sub>16</sub>
3000	49 <sup>5</sup> / <sub>8</sub>	17 <sup>5</sup> / <sub>8</sub>	15 <sup>3</sup> / <sub>4</sub>	15 <sup>5</sup> / <sub>8</sub>	22 <sup>1</sup> / <sub>16</sub>	11	21	19 <sup>13</sup> / <sub>16</sub>
3600	49 <sup>5</sup> / <sub>8</sub>	17 <sup>5</sup> / <sub>8</sub>	15 <sup>3</sup> / <sub>4</sub>	15 <sup>5</sup> / <sub>8</sub>	22 <sup>1</sup> / <sub>16</sub>	11	21	19 <sup>13</sup> / <sub>16</sub>
4200	49 <sup>5</sup> / <sub>8</sub>	21 <sup>1</sup> / <sub>8</sub>	19 <sup>1</sup> / <sub>4</sub>	19 <sup>1</sup> / <sub>8</sub>	22 <sup>1</sup> / <sub>16</sub>	11	21	19 <sup>13</sup> / <sub>16</sub>
4800	49 <sup>5</sup> / <sub>8</sub>	21 <sup>1</sup> / <sub>8</sub>	19 <sup>1</sup> / <sub>4</sub>	19 <sup>1</sup> / <sub>8</sub>	22 <sup>1</sup> / <sub>16</sub>	11	21	19 <sup>13</sup> / <sub>16</sub>
6000	53 <sup>7</sup> / <sub>16</sub>	21 <sup>1</sup> / <sub>8</sub>	19 <sup>1</sup> / <sub>4</sub>	19 <sup>1</sup> / <sub>8</sub>	22 <sup>1</sup> / <sub>16</sub>	11	21	19 <sup>13</sup> / <sub>16</sub>
FEM4P (mm SI Metric)								
Unit Size	A	B	C	D	E	F	G	H
1800	1084	364	316	313	560	279	533	503
2400	1084	364	316	313	560	279	533	503
3000	1261	448	400	397	560	279	533	503
3600	1261	448	400	397	560	279	533	503
4200	1261	537	489	486	560	279	533	503
4800	1261	537	489	486	560	279	533	503
6000	1357	537	489	486	560	279	533	503

**CLEARANCES AND UNIT DIMENSIONS – FSM4P, FSU4P**

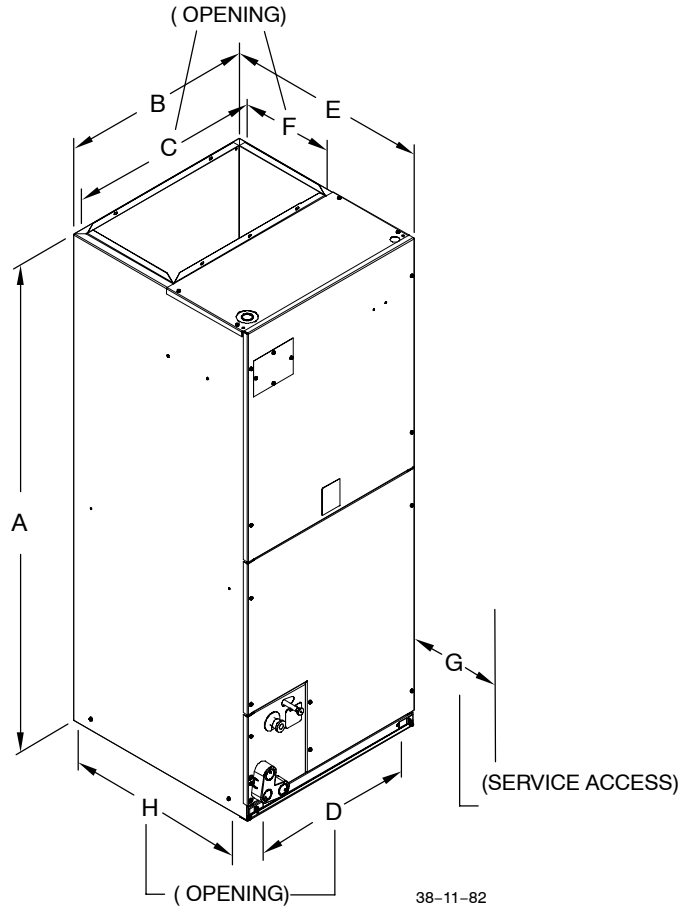

REQUIRED CLEARANCES – ALL MODELS inches (mm)								
No Heaters	All Sides	0						
	From Supply Duct	0						
With Heaters	All Sides	0						
	From First 3 feet of Supply Duct to Combustibles	1 (25)						
	From Supply Duct to Combustibles after 3 feet	0						
FSM4P, FSU4P inches (English)								
Unit Size	A	B	C	D	E	F	G	H
1800	47 <sup>5</sup> / <sub>8</sub>	17 <sup>5</sup> / <sub>8</sub>	15 <sup>3</sup> / <sub>4</sub>	15 <sup>5</sup> / <sub>8</sub>	22 <sup>1</sup> / <sub>16</sub>	11	21	19 <sup>13</sup> / <sub>16</sub>
2400	49 <sup>5</sup> / <sub>8</sub>	17 <sup>5</sup> / <sub>8</sub>	15 <sup>3</sup> / <sub>4</sub>	15 <sup>5</sup> / <sub>8</sub>	22 <sup>1</sup> / <sub>16</sub>	11	21	19 <sup>13</sup> / <sub>16</sub>
3000	53 <sup>7</sup> / <sub>16</sub>	21 <sup>1</sup> / <sub>8</sub>	19 <sup>1</sup> / <sub>4</sub>	19 <sup>1</sup> / <sub>8</sub>	22 <sup>1</sup> / <sub>16</sub>	11	21	19 <sup>13</sup> / <sub>16</sub>
3600	53 <sup>7</sup> / <sub>16</sub>	21 <sup>1</sup> / <sub>8</sub>	19 <sup>1</sup> / <sub>4</sub>	19 <sup>1</sup> / <sub>8</sub>	22 <sup>1</sup> / <sub>16</sub>	11	21	19 <sup>13</sup> / <sub>16</sub>
4200	49 <sup>5</sup> / <sub>8</sub>	21 <sup>1</sup> / <sub>8</sub>	19 <sup>1</sup> / <sub>4</sub>	19 <sup>1</sup> / <sub>8</sub>	22 <sup>1</sup> / <sub>16</sub>	11	21	19 <sup>13</sup> / <sub>16</sub>
4800	53 <sup>7</sup> / <sub>16</sub>	24 <sup>11</sup> / <sub>16</sub>	22 <sup>3</sup> / <sub>4</sub>	22 <sup>11</sup> / <sub>16</sub>	22 <sup>1</sup> / <sub>16</sub>	11	24	19 <sup>13</sup> / <sub>16</sub>
FSM4P, FSU4P mm (SI Metric)								
Unit Size	A	B	C	D	E	F	G	H
1800	1210	448	400	397	560	279	533	503
2400	1261	448	400	397	560	279	533	503
3000	1357	537	489	486	560	279	533	503
3600	1357	537	489	486	560	279	533	503
4200	1261	537	489	486	560	279	533	503
4800	1357	627	578	576	560	279	610	503

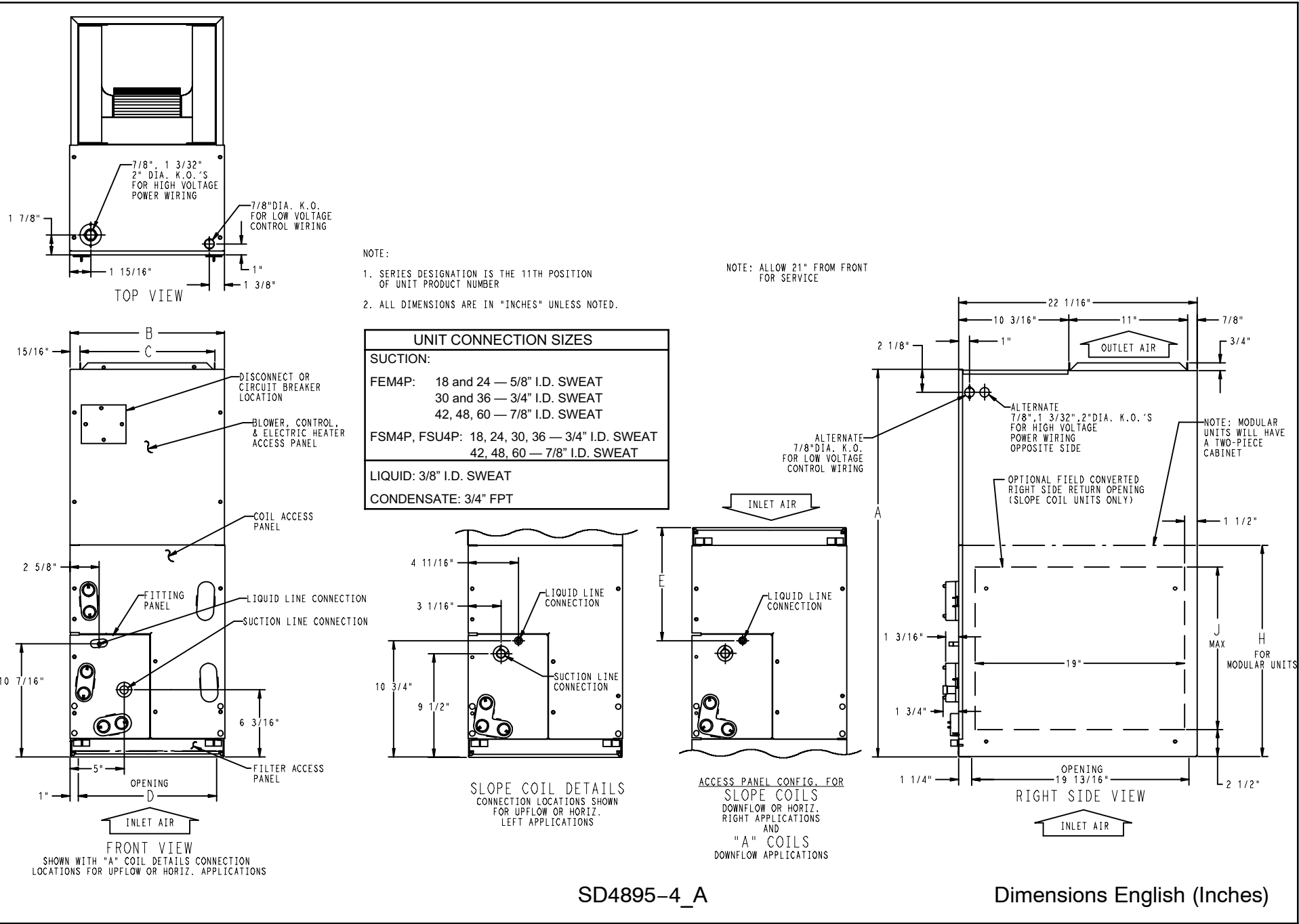

SD4895-4\_A

SLOPE COIL

- NOTES:  
 1. CONDENSATE PAN DRAIN CAPS NOT SHOWN FOR CLARITY.  
 2. ALL DIMENSIONS ARE IN "INCHES" UNLESS NOTED.

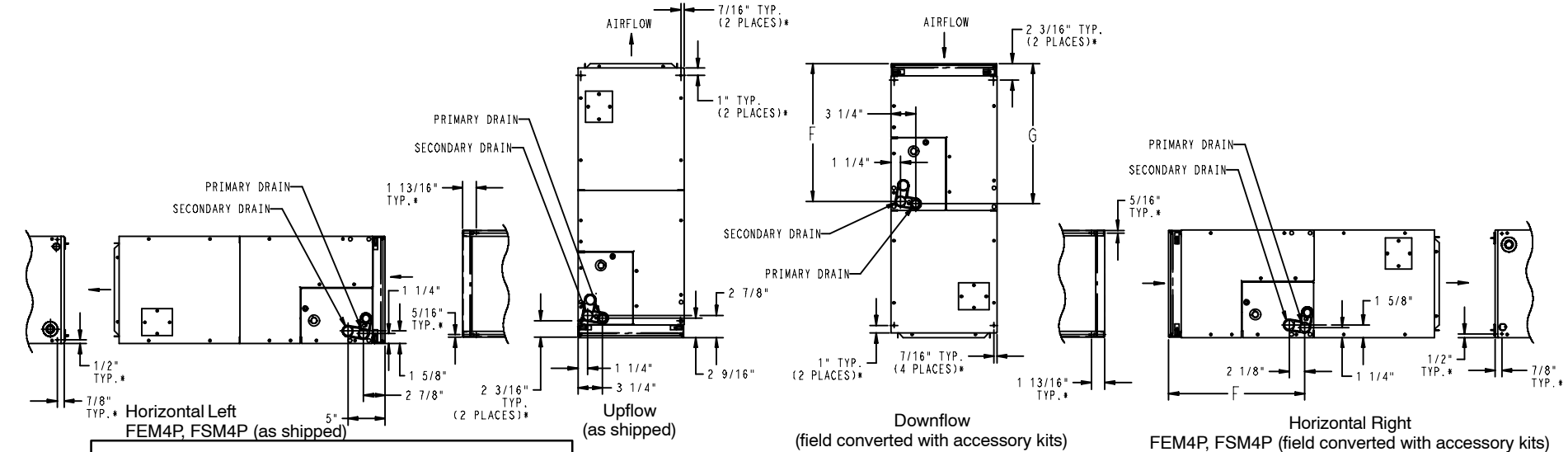

\* HORIZONTAL MOUNT LOCATIONS - DIMPLES PROVIDED IN TOP PANEL, AND BACK OF CABINET. IN CABINET BOTTOM, HOLES PROVIDED .136" DIA. HORIZONTAL HANGING HARDWARE TO BE FIELD SUPPLIED.

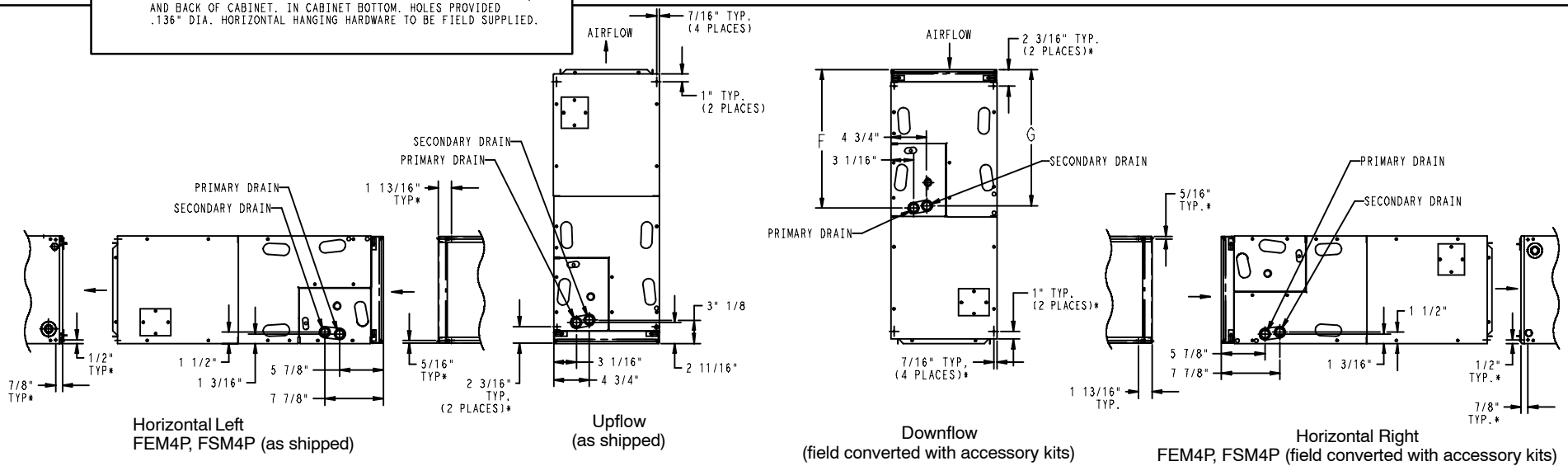

A-COIL

SD4895-4\_A

Dimensions English (Inches)

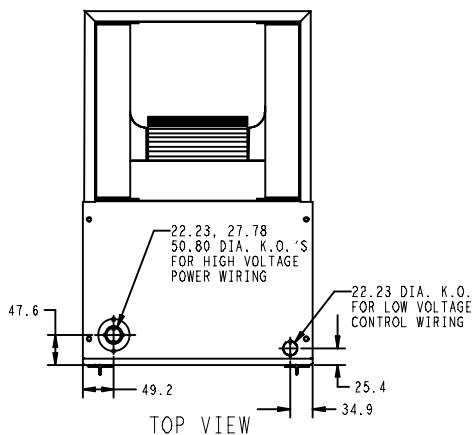

NOTE:

1. SERIES DESIGNATION IS THE 11TH POSITION OF UNIT PRODUCT NUMBER
2. ALL DIMENSIONS ARE IN "MM" UNLESS NOTED.

NOTE: ALLOW 533.4 FROM FRONT FOR SERVICE

UNIT CONNECTION SIZES	
SUCTION:	
FEM4P:	18 and 24 — 15.88 I.D. SWEAT 30 and 36 — 19.05 I.D. SWEAT 42, 48, 60 — 22.23 I.D. SWEAT
FSM4P, FSU4P:	18, 24, 30, 36 — 19.05 I.D. SWEAT 42, 48, 60 — 22.23 I.D. SWEAT
LIQUID: 9.53 I.D. SWEAT	
CONDENSATE: 19.0 FPT	

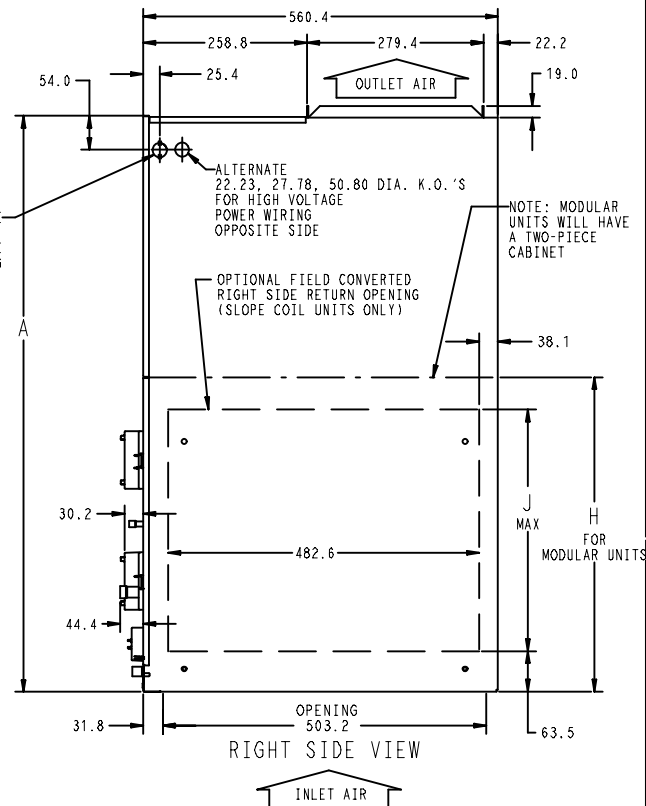
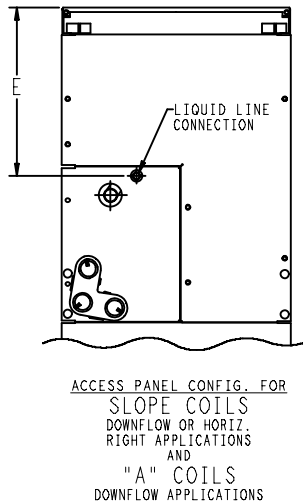
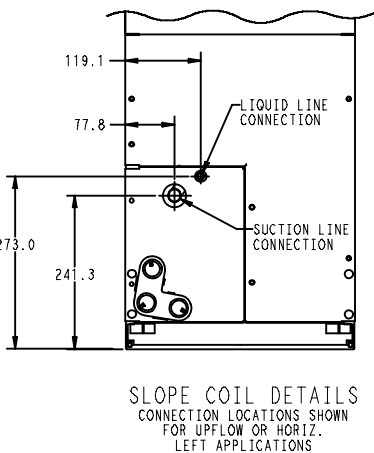

SD4895-4\_A

Dimensions MM (SI Metric)

SLOPE COIL

- NOTES:  
 1. CONDENSATE PAN DRAIN CAPS NOT SHOWN FOR CLARITY.  
 2. ALL DIMENSIONS ARE IN "MM" UNLESS NOTED.

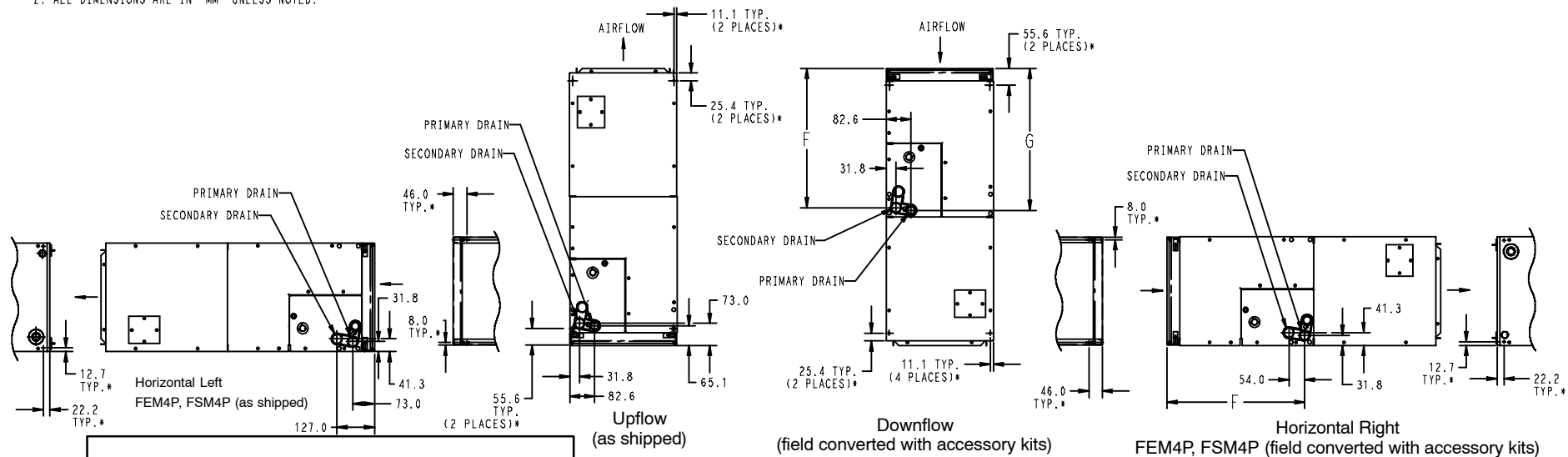

\* HORIZONTAL MOUNT LOCATIONS - DIMPLES PROVIDED IN TOP PANEL, AND BACK OF CABINET. IN CABINET BOTTOM, HOLES PROVIDED 3.45 DIA. HORIZONTAL HANGING HARDWARE TO BE FIELD SUPPLIED.

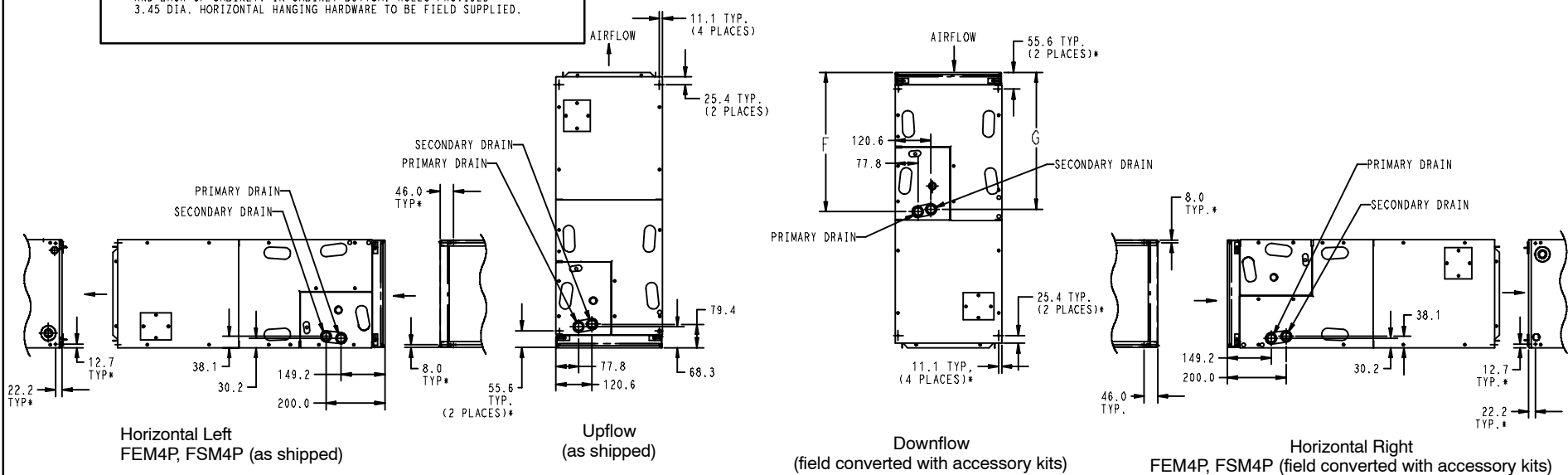

A-COIL  
SD4895-4\_A

Dimensions MM (SI Metric)

DIMENSIONAL DATA (refer to drawings)																
Model	Size (tons)	Dimensions inches (English)											Coil Type	Ship. WT lbs.		
		A	B	C	D	E	F	G	H	J	Suct.	Liquid				
FEM4P1800A	1½	42 <sup>1</sup> / <sub>16</sub>	14 <sup>5</sup> / <sub>16</sub>	12 <sup>7</sup> / <sub>16</sub>	12 <sup>5</sup> / <sub>16</sub>	10 <sup>7</sup> / <sub>16</sub>	18 <sup>1</sup> / <sub>8</sub>	18 <sup>5</sup> / <sub>8</sub>	—	12	5/8	3/8	Slope	112		
FSM4P1800A FSU4P1800A		47 <sup>5</sup> / <sub>8</sub>	17 <sup>5</sup> / <sub>8</sub>	15 <sup>3</sup> / <sub>4</sub>	15 <sup>5</sup> / <sub>8</sub>	15 <sup>5</sup> / <sub>8</sub>	23 <sup>3</sup> / <sub>8</sub>	23 <sup>5</sup> / <sub>8</sub>		—	—			3/4	117	
FEM4P2400A		2	42 <sup>1</sup> / <sub>16</sub>	14 <sup>5</sup> / <sub>16</sub>	12 <sup>7</sup> / <sub>16</sub>	12 <sup>5</sup> / <sub>16</sub>	10 <sup>7</sup> / <sub>16</sub>	18 <sup>1</sup> / <sub>8</sub>		18 <sup>5</sup> / <sub>8</sub>	—			12	5/8	3/8
FSM4P2400A FSU4P2400A	49 <sup>5</sup> / <sub>8</sub>		17 <sup>5</sup> / <sub>8</sub>	15 <sup>3</sup> / <sub>4</sub>	15 <sup>5</sup> / <sub>8</sub>	15 <sup>5</sup> / <sub>8</sub>	23 <sup>3</sup> / <sub>8</sub>	23 <sup>5</sup> / <sub>8</sub>	—	—		3/4	128			
FEM4P3000A	2½		49 <sup>5</sup> / <sub>8</sub>	17 <sup>5</sup> / <sub>8</sub>	15 <sup>3</sup> / <sub>4</sub>	15 <sup>5</sup> / <sub>8</sub>	15 <sup>5</sup> / <sub>8</sub>	23 <sup>3</sup> / <sub>8</sub>	23 <sup>5</sup> / <sub>8</sub>	—		17	3/4	3/8	Slope	
FSM4P3000A FSU4P3000A		53 <sup>7</sup> / <sub>16</sub>	21 <sup>1</sup> / <sub>8</sub>	19 <sup>1</sup> / <sub>4</sub>	19 <sup>1</sup> / <sub>8</sub>	19 <sup>3</sup> / <sub>16</sub>	26 <sup>15</sup> / <sub>16</sub>	27 <sup>1</sup> / <sub>2</sub>	—		—	145				
FEM4P3600A		3	49 <sup>5</sup> / <sub>8</sub>	17 <sup>5</sup> / <sub>8</sub>	15 <sup>3</sup> / <sub>4</sub>	15 <sup>5</sup> / <sub>8</sub>	15 <sup>5</sup> / <sub>8</sub>	23 <sup>3</sup> / <sub>8</sub>	23 <sup>5</sup> / <sub>8</sub>		—	17				3/4
FSM4P3600A FSU4P3600A	53 <sup>7</sup> / <sub>16</sub>		21 <sup>1</sup> / <sub>8</sub>	19 <sup>1</sup> / <sub>4</sub>	19 <sup>1</sup> / <sub>8</sub>	19 <sup>3</sup> / <sub>16</sub>	26 <sup>15</sup> / <sub>16</sub>	27 <sup>1</sup> / <sub>2</sub>	—	—		148				
FEM4P4200A	3½		49 <sup>5</sup> / <sub>8</sub>	21 <sup>1</sup> / <sub>8</sub>	19 <sup>1</sup> / <sub>4</sub>	19 <sup>1</sup> / <sub>8</sub>	15 <sup>1</sup> / <sub>16</sub>	23 <sup>7</sup> / <sub>16</sub>	23 <sup>3</sup> / <sub>8</sub>	—		—	7/8	3/8	"A"	
FSM4P4200A FSU4P4200A		49 <sup>5</sup> / <sub>8</sub>	21 <sup>1</sup> / <sub>8</sub>	19 <sup>1</sup> / <sub>4</sub>	19 <sup>1</sup> / <sub>8</sub>	15 <sup>1</sup> / <sub>16</sub>	23 <sup>7</sup> / <sub>16</sub>	23 <sup>3</sup> / <sub>8</sub>	—		—					156
FEM4P4800A		4	49 <sup>5</sup> / <sub>8</sub>	21 <sup>1</sup> / <sub>8</sub>	19 <sup>1</sup> / <sub>4</sub>	19 <sup>1</sup> / <sub>8</sub>	15 <sup>1</sup> / <sub>16</sub>	23 <sup>7</sup> / <sub>16</sub>	23 <sup>3</sup> / <sub>8</sub>		—					—
FSM4P4800A FSU4P4800A	53 <sup>7</sup> / <sub>16</sub>		24 <sup>1</sup> / <sub>16</sub>	22 <sup>3</sup> / <sub>4</sub>	22 <sup>1</sup> / <sub>16</sub>	19 <sup>1</sup> / <sub>2</sub>	27 <sup>1</sup> / <sub>4</sub>	26 <sup>15</sup> / <sub>16</sub>	—	—		182				
FEM4P6000A	5		53 <sup>7</sup> / <sub>16</sub>	21 <sup>1</sup> / <sub>8</sub>	19 <sup>1</sup> / <sub>4</sub>	19 <sup>1</sup> / <sub>8</sub>	19 <sup>1</sup> / <sub>2</sub>	27 <sup>1</sup> / <sub>4</sub>	26 <sup>15</sup> / <sub>16</sub>	28 <sup>5</sup> / <sub>16</sub>		—	7/8	3/8	"A"	

DIMENSIONAL DATA (refer to drawings)																
Model	Size (tons)	Dimensions mm (SI Metric)											Coil Type	Ship. WT kg		
		A	B	C	D	E	F	G	H	J	Suct.	Liquid				
FEM4P1800A	1½	1084	364	316	313	265	460	473	—	305	16	10	Slope	51		
FSM4P1800A FSU4P1800A		1210	448	400	397	391	587	600		—	—			19	53	
FEM4P2400A		2	1084	364	316	313	265	460		473	—			305	16	10
FSM4P2400A FSU4P2400A	1261		448	400	397	391	587	600	—	—		19	58			
FEM4P3000A	2½		1261	448	400	397	391	587	600	—		305	19	10	Slope	
FSM4P3000A FSU4P3000A		1357	537	489	486	487	684	699	—		—	66				
FEM4P3600A		3	1261	448	400	397	391	587	600		—	305				19
FSM4P3600A FSU4P3600A	1357		537	489	486	487	684	699	—	—		67				
FEM4P4200A	3½		1261	537	489	486	399	595	587	—		—	22	10	"A"	
FSM4P4200A FSU4P4200A		1261	537	489	486	399	595	587	—		—					71
FEM4P4800A		4	1261	537	489	486	399	595	587		—					—
FSM4P4800A FSU4P4800A	1357		627	578	576	495	692	684	—	—		83				
FEM4P6000A	5		1357	537	489	486	495	692	684	719		—	22	10	"A"	

PHYSICAL DATA								
Model		Size						
		1800	2400	3000	3600	4200	4800	6000
<b>Metering Device** – Factory Installed Piston Size (R-410A)</b>								
FEM4P		52	57	67	70	76	80	90
FSM4P, FSU4P		52	57	67	70	76	80	—
<b>Blower Data</b>								
CFM (nominal)	FEM4P	600	800	1000	1200	1400	1600	1750
	FSM4P, FSU4P	600	800	1000	1200	1400	1600	—
Motor Type	FEM4P	X-13 ECM, 5-speed						
	FSM4P, FSU4P	PSC (Permanent Split Capacitor) 2-speed						
HP	FEM4P	1/3	1/2	1/3	1/2	1/2	3/4	3/4
	FSM4P, FSU4P	1/6	1/4	1/3	1/3	1/2	1/2	—
<b>Filter Size</b>								
FEM4P		13 x 21½		16¾ x 21½		19⅞ x 21½		
FSM4P, FSU4P		16¾ x 21½		19⅞ x 21½			23⅝ x 21½	—
<b>Coil Data – Face Area ft<sup>2</sup> (m<sup>2</sup>)</b>								
FEM4P		2.23 (0.21)	2.23 (0.21)	2.97 (0.28)	2.97 (0.28)	4.45 (0.41)	4.45 (0.41)	5.93 (0.55)
FSM4P, FSU4P		2.97 (0.28)	2.97 (0.28)	3.46 (0.32)	3.46 (0.32)	4.45 (0.41)	5.93 (0.55)	—
<b>Refrigerant Line Connections (sweat)</b>								
FEM4P	Liquid inch (mm)	3/8 (10)						
	Suction inch (mm)	5/8 (16)	5/8 (16)	3/4 (19)	3/4 (19)	7/8 (22)	7/8 (22)	7/8 (22)
FSM4P, FSU4P	Liquid inch (mm)	3/8 (10)						
	Suction inch (mm)	3/4 (19)	3/4 (19)	3/4 (19)	3/4 (19)	7/8 (22)	7/8 (22)	—

ELECTRICAL DATA, FAN COIL ONLY WITHOUT ELECTRIC HEAT			
Model	208/230V, single phase, 60 Hz		
	Motor Full Load Amps (FLA)	Minimum Circuit Ampacity (MCA)	Maximum Fuse/Ckt Bkr Amps (Max OverCurrent Protection – MOCP)
FEM4P1800	2.8	3.5	15
FSM4P1800, FSU4P1800	0.9	1.2	15
FEM4P2400	4.1	5.1	15
FSM4P2400, FSU4P2400	1.4	1.8	15
FEM4P3000	2.8	3.5	15
FSM4P3000, FSU4P3000	1.4	1.8	15
FEM4P3600	4.1	5.1	15
FSM4P3600, FSU4P3600	1.7	2.2	15
FEM4P4200	4.1	5.1	15
FSM4P4200, FSU4P4200	2.8	3.5	15
FEM4P4800	6.0	7.5	15
FSM4P4800, FSU4P4800	2.7	3.4	15
FEM4P6000	6.0	7.5	15

\*\*Always check piston size on indoor unit to see if it matches required piston on outdoor unit nameplate. If it does not match, replace indoor piston with piston size marked on outdoor unit nameplate.

AIRFLOW PERFORMANCE – CFM at a given Speed and Static reading							
Model	Blower Speed	Total Static (inches water column)					
		0.10	0.20	0.30	0.40	0.50	0.60
FEM4P1800	Tap 5	767	739	702	669	620	565
	Tap 4	614	569	534	486	436	398
	Tap 3	701	660	616	581	537	499
	Tap 2	614	569	534	486	436	398
	Tap 1	614	569	534	486	436	398
FEM4P2400	Tap 5	969	936	892	835	763	676
	Tap 4	826	795	766	743	706	660
	Tap 3	826	795	766	743	706	660
	Tap 2	701	660	616	581	537	499
	Tap 1	617	592	552	507	472	420
FEM4P3000	Tap 5	1108	1090	1065	1034	1009	974
	Tap 4	1026	1000	969	938	899	865
	Tap 3	1026	1000	969	938	899	865
	Tap 2	909	873	842	799	762	724
	Tap 1	825	795	757	722	674	634
FEM4P3600	Tap 5	1301	1276	1245	1218	1176	1121
	Tap 4	1227	1191	1169	1143	1105	1074
	Tap 3	1227	1191	1169	1143	1105	1074
	Tap 2	1087	1062	1030	1001	966	930
	Tap 1	1026	1000	969	938	899	865
FEM4P4200	Tap 5	1560	1544	1507	1464	1424	1358
	Tap 4	1419	1397	1358	1320	1279	1239
	Tap 3	1419	1397	1358	1320	1279	1239
	Tap 2	1249	1220	1184	1142	1093	1052
	Tap 1	1242	1205	1158	1110	1069	1026
FEM4P4800	Tap 5	1743	1712	1679	1642	1610	1574
	Tap 4	1669	1634	1599	1564	1531	1499
	Tap 3	1669	1634	1599	1564	1531	1499
	Tap 2	1452	1413	1377	1339	1308	1271
	Tap 1	1300	1256	1221	1182	1142	1101
FEM4P6000	Tap 5	1897	1867	1836	1808	1774	1736
	Tap 4	1817	1785	1757	1724	1693	1655
	Tap 3	1817	1785	1757	1724	1693	1655
	Tap 2	1657	1621	1589	1557	1518	1474
	Tap 1	1443	1412	1377	1332	1286	1243

AIRFLOW PERFORMANCE – CFM at a given Speed and Static reading													
Model	Blower Speed	Total Static (inches water column)											
		0.10		0.20		0.30		0.40		0.50		0.60	
		208V	230V	208V	230V	208V	230V	208V	230V	208V	230V	208V	230V
FSM4P1800	High	742	825	707	768	642	714	568	648	466	526	403	434
FSU4P1800	Low	541	608	480	564	417	511	357	431	299	363	n/a	304
FSM4P2400	High	1041	1112	969	1030	888	936	774	791	573	654	341	438
FSU4P2400	Low	874	1014	838	953	781	868	684	740	506	573	341	418
FSM4P3000	High	1256	1327	1186	1242	1071	1132	952	1005	704	791	459	482
FSU4P3000	Low	965	1117	949	1074	916	1019	805	902	575	637	396	447
FSM4P3600	High	1306	1490	1264	1418	1207	1338	1135	1241	1043	1127	842	937
FSU4P3600	Low	1164	1335	1144	1290	1108	1226	1052	1148	970	1048	697	855
FSM4P4200	High	1723	1768	1639	1681	1544	1576	1435	1465	1309	1340	1144	1182
FSU4P4200	Low	1387	1543	1358	1488	1311	1410	1237	1315	1137	1200	997	1047
FSM4P4800	High	1902	1941	1803	1867	1706	1767	1593	1648	1472	1512	1303	1371
FSU4P4800	Low	1671	1777	1630	1711	1563	1630	1479	1528	1370	1412	1218	1266

■ – Airflow outside 450 cfm/ton.

**NOTES:**

- Airflow based upon dry coil at 230v with factory-approved filter and electric heater (2 element heater sizes 1800 through 3600, 3 element heater sizes 4200 through 6000). For FEM4P models, airflow at 208 volts is approximately the same as 230 volts because the X13 motor is a constant torque motor. The torque doesn't drop off at the speeds the motor operates.
- To avoid potential for condensate blowing out of drain pan prior to making drain trap:  
Return static pressure must be less than 0.40 in. wc.  
Horizontal applications of 4200 – 6000 sizes must have supply static greater than 0.20 in. wc.
- Airflow above 400 cfm/ton on 4800–6000 size could result in condensate blowing off coil or splashing out of drain pan.

PRESSURE DROP ACROSS FILTER (inches of water column)									
Model FEM4P	CFM								
	400	600	800	1000	1200	1400	1600	1800	2000
1800	0.02	0.044	0.075	—	—	—	—	—	—
2400, 3000	—	0.022	0.048	0.072	0.100	—	—	—	—
3600 4200, 4800	—	—	—	0.051	0.070	0.092	0.120	0.152	—
6000	—	—	—	—	—	—	0.086	0.105	0.130

Models FSM4P, FSU4P	CFM								
	400	600	800	1000	1200	1400	1600	1800	2000
1800, 2400	0.012	0.022	0.048	0.072	—	—	—	—	—
3000, 3600, 4200	—	—	0.036	0.051	0.07	0.092	0.12	—	—
4800	—	—	—	—	—	0.073	0.086	0.105	0.13

STATIC PRESSURE CORRECTION FROM DRY TO WET COIL (inches of water column)																
Model FEM4P	CFM															
	500	600	700	800	900	1000	1100	1200	1300	1400	1500	1600	1700	1800	1900	2000
1800	0.034	0.049	0.063	—	—	—	—	—	—	—	—	—	—	—	—	—
2400	0.034	0.049	0.063	0.076	0.089	—	—	—	—	—	—	—	—	—	—	—
3000	—	—	—	0.049	0.059	0.070	0.080	—	—	—	—	—	—	—	—	—
3600	—	—	—	—	—	0.070	0.080	0.090	0.099	—	—	—	—	—	—	—
4200	—	—	—	—	—	—	—	0.049	0.056	0.063	0.070	—	—	—	—	—
4800	—	—	—	—	—	—	—	—	—	0.063	0.070	0.076	0.083	0.090	—	—
6000	—	—	—	—	—	—	—	—	—	—	—	0.049	0.054	0.059	0.065	0.070

Models FSM4P, FSU4P	CFM															
	500	600	700	800	900	1000	1100	1200	1300	1400	1500	1600	1700	1800	1900	2000
1800	0.016	0.027	0.038	—	—	—	—	—	—	—	—	—	—	—	—	—
2400	0.016	0.027	0.038	0.049	0.059	—	—	—	—	—	—	—	—	—	—	—
3000	—	—	—	0.036	0.046	0.055	0.064	—	—	—	—	—	—	—	—	—
3600	—	—	—	—	—	0.055	0.064	0.073	0.081	—	—	—	—	—	—	—
4200	—	—	—	—	—	—	—	0.049	0.056	0.063	0.07	—	—	—	—	—
4800	—	—	—	—	—	—	—	—	—	0.038	0.043	0.049	0.054	0.059	—	—

**MINIMUM CFM WHEN USING ELECTRIC HEAT**

Model FEM4P	HEATER kW									
	3	5	8	9	10	15	18	20	24	30
1800	525	525	525	—	600	—	—	—	—	—
2400	700	700	700	—	700	775	—	—	—	—
3000	—	875	875	—	875	875	—	1060	—	—
3600	—	1050	970	970	970	920	—	1040	—	—
4200	—	—	1225	1225	1225	1225	1225	1225	—	—
4800	—	—	1400	1400	1400	1400	1400	1400	1400	1400
6000	—	—	1750	1750	1750	1750	1750	1750	1750	1750

**Note:** Speed Tap 4 (white wire) is used for electric heat only. White wire must remain on tap 4.

Models FSM4P, FSU4P	HEATER kW									
	3	5	8	9	10	15	18	20	24	30
1800	525	525	525	—	600	—	—	—	—	—
2400	700	700	700	—	700	775	—	—	—	—
3000	—	875	875	—	875	875	—	1060	—	—
3600	—	1050	970	970	970	920	—	1040	—	—
4200	—	—	1225	1225	1225	1225	1225	1225	—	—
4800	—	—	1400	1400	1400	1400	1400	1400	1400	1400
6000	—	—	1750	1750	1750	1750	1750	1750	1750	1750

**Note:** Values indicate low or medium speed.

**STATIC PRESSURE CORRECTION FOR ELECTRIC HEATERS (inches of water column)**

Airflow performance chart was developed using fan coils with 10 kW electric heater (2 elements) in the 1800 – 3600 model sizes, and 15 kW electric heaters (3 elements) in the 4200 – 6000 model sizes. When using a different number of heater elements, adjust the static pressure numbers by adding or subtracting the values in this table (for a given CFM, more electric heater elements create higher static pressure drop).

Model Size	Heater kW					
	No Heater	3 or 5	8 or 10	9 or 15	20	18, 24, or 30
	Number of Heat Elements					
	0	1	2	3	4	6
1800	+0.02	+0.01	0	-0.02	-0.04	-
2400	+0.02	+0.01	0	-0.02	-0.04	-
3000	+0.02	+0.01	0	-0.02	-0.04	-
3600	+0.02	+0.01	0	-0.02	-0.04	-
4200	+0.04	-	+0.02	0	-0.02	-0.10
4800	+0.04	-	+0.02	0	-0.02	-0.10
6000	+0.04	-	+0.02	0	-0.02	-0.10

**TABLE 3 - ELECTRIC HEATER ELECTRICAL DATA**

Heater Model	Heater kW		Phase	Internal Circuit Protection	Heater Amps 208/230V		Branch Circuit 208/230V						
							Minimum Circuit Ampacity (MCA) ☆			Max Fuse/Ckt Bkr Amps (Max OverCurrent Protection)			
	230V	208V			Single Circuit	Dual Circuit		Single Circuit	Dual Circuit		Single Circuit	Dual Circuit	
						L1, L2	L3, L4		L1, L2	L3, L4		L1, L2	L3, L4
EHK05AKN*	5	3.8	1	None	18.1 / 20.0	-	-	26.0 / 28.4	-	-	30 / 30	-	-
EHK05AKN**	5	3.8	1	None	18.1 / 20.0	-	-	31.2 / 33.5	-	-	35 / 35	-	-
EHK05AKB*	5	3.8	1	Ckt Bkr	18.1 / 20.0	-	-	26.0 / 28.4	-	-	30 / 30	-	-
EHK05AKB**	5	3.8	1	Ckt Bkr	18.1 / 20.0	-	-	31.2 / 33.5	-	-	35 / 35	-	-
EHK07AKN	8	6.0	1	None	28.9 / 32.0	-	-	44.7 / 48.5	-	-	45 / 50	-	-
EHK07AKB	8	6.0	1	Ckt Bkr	28.9 / 32.0	-	-	44.7 / 48.5	-	-	45 / 50	-	-
EHK09AKCN†	9	6.8	1	None	32.8 / 36.0	-	-	49.5 / 53.5	-	-	50 / 60	-	-
			3	None	18.8 / 20.8	-	-	32.0 / 34.5	-	-	35 / 35	-	-
EHK10AKN	10	7.5	1	None	36.2 / 40.0	-	-	53.8 / 58.5	-	-	60 / 60	-	-
EHK10AKB	10	7.5	1	Ckt Bkr	36.2 / 40.0	-	-	53.8 / 58.5	-	-	60 / 60	-	-
EHK15AKF	15	11.3	1	Fuse	54.2 / 59.9	36.2 / 40.0	18.1 / 20.0	76.3 / 83.4	53.8 / 58.5	22.7 / 25.0	80 / 90	60 / 60	25 / 25
EHK15AKB	15	11.3	1	Ckt Bkr	-	36.2 / 40.0	18.1 / 20.0	-	53.8 / 58.5	22.7 / 25.0	-	60 / 60	25 / 25
EHK15AHN	15	11.3	3	None	31.3 / 34.6	-	-	47.7 / 51.8	-	-	50 / 60	-	-
EHK18AHN	18	13.5	3	None	37.6 / 41.5	-	-	55.5 / 60.4	-	-	60 / 70	-	-
EHK20AKF	20	15.0	1	Fuse	72.3 / 79.9	36.2 / 40.0	36.2 / 40.0	98.9 / 108.4	53.8 / 58.5	45.3 / 50.0	100 / 110	60 / 60	50 / 50
EHK20AKB	20	15.0	1	Ckt Bkr	-	36.2 / 40.0	36.2 / 40.0	-	53.8 / 58.5	45.3 / 50.0	-	60 / 60	50 / 50
EHK25AHCF‡	24	18.0	3	Fuse	50.1 / 55.4	-	-	71.2 / 77.8	-	-	80 / 80	-	-
			1	Fuse	86.7 / 95.5	-	-	116.9 / 127.9	-	-	125 / 150	-	-
EHK30AHCF‡	30	22.5	3	Fuse	62.6 / 69.2	-	-	86.8 / 95.0	-	-	90 / 100	-	-
			1	Fuse	109 / 120	-	-	144.8 / 158.5	-	-	150 / 175	-	-

**TABLE 4 - FIELD MULTIPOINT WIRING OR 24 AND 30 KW SINGLE PHASE**

Heater Model	Heater kW		P H A S E	Heater Amps 208/230V			Minimum Circuit Ampacity 208/230V ☆			Minimum Wire Size (AWG) 208/230V‡			Min Gnd Wire Size 208/230V	Max Fuse/Ckt Bkr Amps 208/230V			Max Wire Length 208/230V (FT)‡‡		
	230V	208V		L1, L2	L3, L4	L5, L6	L1, L2	L3, L4	L5, L6	L1, L2	L3, L4	L5, L6		L1, L2	L3, L4	L5, L6			
EHK25AHCF‡	24	18.0	1	28.9/32.0	28.9/32.0	28.9/32.0	44.7/48.5	36.2/40.0	36.2/40.0	8/8	8/8	8/8	10/10	45/50	40/40	40/40	59/60	73/73	73/73
EHK30AHCF‡	30	22.5	1	36.2/40.0	36.2/40.0	36.2/40.0	53.8/58.5	45.3/50.0	45.3/50.0	6/6	8/8	8/8	10/10	60/60	50/50	50/50	78/80	59/59	59/59

Notes:

- \* When used with Fan Coil model sizes 2400, 3600
- \*\* When used with Fan Coil model sizes 4200, 4800, 6000
- ☆ Includes blower motor amps of largest Fan Coil used with heater
- † Supplied as single phase, field convertible to 3-phase
- ‡ Supplied as 3-phase, field convertible to single phase, single or multiple supply circuits
- ‡‡ Length shown is as measured one way along wire path between unit and service panel for a voltage drop not to exceed 2%

ACCESSORIES			
Description	Part Number	Use with models	
		FSM4P & FSU4P models	FEM4P models
Disconnect Kit	EBAC01DSC	use with All Heaters 3 kW thru 10 kW	
Downflow Base Kit	EBAC01NCB	-	1800, 2400
	EBAC02NCB	1800, 2400	3000, 3600
	EBAC03NCB	3000, 3600, 4200, 4800	4200, 4800, 6000
Downflow Conversion Kit – Slope Coil	EBAC01DFS	1800, 2400, 3000, 3600	1800, 2400, 3000, 3600
Downflow Conversion Kit – “A” Coil	EBAC02DFA	4200, 4800	4200, 4800, 6000
Single Point Wiring Kit	EBAC01SPK	only for use with 15 kW & 20 kW fused heaters	
Single Point Wiring Kit – Square D® Jumper Bar Assembly	AMFK20SPA or Square D® part # QOU14100JBAF	Only for use with EHK15AKB and EHK20AKB breaker heaters	
Permanent Filter Kit (box of 12)	EBAC01FKS	-	1800, 2400
	EBAC01FKM	1800, 2400	3000, 3600
	EBAC01FKL	3000, 3600, 4200	4200, 4800, 6000
	EBAC01FKX	4800	-
PVC Condensate Trap Kit (box of 50)	EBAC01CTK	ALL	ALL
Downflow Gasket Kit	EBAC01GSK	ALL	ALL (required for horizontal right and downflow)
TXV Kit, R-410A	NAEA40501TX	1800, 2400, 3000	1800, 2400, 3000
	NAEA40601TX	3600, 4200	3600, 4200
	NAEA40701TX	4800	4800, 6000
TXV Kit, R-22	NAEA20101TX	1800, 2400, 3000, 3600, 4200	1800, 2400, 3000, 3600, 4200
	NAEA20201TX	4800	4800
	NAEA20301TX	-	6000

ELECTRIC HEATERS		
Part Number	Description	Use with Model Sizes
EHK05AKN	5 kW, single phase, no internal circuit protection	ALL
EHK05AKB	5 kW, single phase, with circuit breakers	ALL
EHK07AKN	8 kW, single phase, no internal circuit protection	ALL
EHK07AKB	8 kW, single phase, with circuit breakers	ALL
EHK09AKCN	9 kW, supplied as single phase, field convertible to 3-phase, no internal circuit protection	3600, 4200, 4800, 6000
EHK10AKN	10 kW, single phase, no internal circuit protection	ALL
EHK10AKB	10 kW, single phase, with circuit breakers	ALL
EHK15AKF	15 kW, single phase, with fuses	2400, 3000, 3600, 4200, 4800, 6000
EHK15AKB	15 kW, single phase, with circuit breakers	2400, 3000, 3600, 4200, 4800, 6000
EHK15AHN	15 kW, 3-phase, no internal circuit protection	3600, 4200, 4800, 6000
EHK18AHN	18 kW, 3-phase, no internal circuit protection	4200, 4800, 6000
EHK20AKF	20 kW, single phase, with fuses	3000, 3600, 4200, 4800, 6000
EHK20AKB	20 kW, single phase, with circuit breakers	3000, 3600, 4200, 4800, 6000
EHK25AHCF	24 kW, supplied as 3-phase, field convertible to single phase, with fuses	4800, 6000
EHK30AHCF	30 kW, supplied as 3-phase, field convertible to single phase, with fuses	4800, 6000

International Comfort Products, LLC  
 Lewisburg, Tennessee 37091 USA  
[www.DayandNight.com](http://www.DayandNight.com)